



International Bakery Equipment Pty. Ltd.

INSTRUCTION MANUAL



FULLY-AUTOMATIC BUN DIVIDER ROUNDER MODEL: FABDR

Contents

1. General Information:

- 1- Documentation supplied
 - 2- Contact details
 - 3- Use of this manual
 - 4- Intellectual property rights
 - 5- Warranty terms and conditions
 - 6- Machine specifications
 - 7- Machine identification details
 - 8- Main components of the machine
 - 9- Safeguards
 - 10- Intended operation
-

2. Transport and Installation:

- 1- Transport
 - 2- Installation
 - 3- Testing & Safeguards
-

3. Machine Operation:

- 1- Intended operation
 - 2- Control components
 - 3- Dividing operation
-

4. Cleaning & Maintenance:

- 1- Cleaning
- 2- Maintenance
- 3- Spare parts list
- 4- Exploded parts drawings

- 5- Electrical diagram
- 6-Hydraulic control diagram

1. General Information:

1.1 Documentation supplied

- Instruction manual
- Spare parts list
- Wiring diagrams

1.2 Contact Details

International Bakery Equipment Pty Ltd (I.B.E.)

Address:

20 Brewer Street,
CLONTARF QLD 4019
Australia

Phone:

1300 099 011 or +61 7 3889 5700

E-Mail:

sales@allaboutbakery.com.au

Web:

www.allaboutbakery.com.au

1.3 Use of this Manual

Please read carefully the information supplied in this manual before installing, operating or carrying out maintenance on this machine.

This manual must be kept in good condition and stored where it can be easily found when required.

1.4 Intellectual Property Rights

This manual contains copyright information. All rights are reserved. No part of this manual can be reproduced or photocopied without prior written permission of International Bakery Equipment Pty Ltd. Permission to use this documentation has only been given to the customer who this manual has been supplied as part of the machine's equipment and only for the purpose of installation, operation and maintenance of the machine to which the manual refers.

International Bakery Equipment Pty Ltd declares that the information contained herein is in accordance with the technical and safety specifications of the machine to which the manual refers. International Bakery Equipment Pty Ltd will not be held responsible for direct or indirect damage or injury to people or objects resulting from the misuse of this documentation or the machine for which it has been intended.

The manufacturer reserves the right to introduce technical modifications or improvements both to the documentation and to the machines without prior notice. The information contained herein refers in particular to the machine specified in section 1.7 "Machine identification details".

1.5 Warranty Terms and Conditions

- Warranty becomes effective from date of delivery.
- Warranty claims may be made by telephone, letter, email or fax. However all verbal claims must be confirmed in writing. I.B.E. Pty Ltd Reserves the right to require return of all claimed defective parts.
- I.B.E. Pty Ltd will ship the part(s) in an expeditious manner as requested.
- Mechanical and Electrical parts are warranted for a period of 12 months from date of delivery.
- During the first 12 months, I.B.E. Pty Ltd will reimburse the Authorized Agent or Purchaser for the cost of reasonable labour during normal working hours, 8.00a.m. – 5.00p.m., to remove the failed part(s) and install the replacement(s). After 12 months all charges will be the Purchasers responsibility.
- After the initial 12 months warranty, any replacement parts are warranted for 3 months excluding labour.
- This Warranty may not be changed or modified and is not subject to any other Warranty expressed or implied by any other Agent, Dealer or Distributor unless approved in writing by I.B.E. Pty Ltd in advance of any claim being filed. This Warranty gives you specific legal rights which vary from State to State.

Note:

I.B.E. Pty Ltd reserves the right to make the final decision on all Warranty coverage questions. The decision of the Company is final.

What is covered under this Warranty:

- Parts that fail due to defects in material workmanship.
- Parts that fail due to faulty assembly by I.B.E. Pty Ltd
- Parts that fail due to improper set-up by I.B.E. Pty Ltd

What is not covered under this Warranty:

- Parts that fail due to improper usage or overloading of the machine.
- Parts that fail due to lack of maintenance.
- Parts that fail due to abuse, misuse or modification.
- Mixer attachments - Bowl, whisk, beater and/or hook.

- Normal wear parts, such as, Conveyor belts, ‘v’ belts, ‘o’ rings and scraper and slicer blades. The Warranty on these parts is, they will be in satisfactory operating condition at time of delivery and initial start-up. Claims in such parts must be made immediately.
- Loss of time, potential revenue and/or profits.
- Personal injury or property damage resulting from the operation of the machine.

1.6 Specifications

Crate Dimensions:

Length (cm)	Width (cm)	Height (cm)	Weight (Kg)
92	83	185	520

Machine Specifications

Model	Dough Capacity Kg Min - Max	Dough Dividing Weight g Min - Max	Motor H.P.	Dimensions			Weight Kg (Net)
				L cm	W cm	H cm	
FA/BDR	900g – 3.6Kg	30g - 120g	2	70	71	164	460

Power Supply Details:

3 Phase, 10amp 4-pin plug top (supplied)

Note:

The Manufacturer will not be Liable for electrical defects, breakdowns or malfunctioning of the machine for the non compliance with the power supply stated.

1.7 Machine Identification Details

Type: Semi-Automatic Bun Divider Rounder
Model:FA BDR

Position of Serial Number Identification Plate(plate not shown) (Fig 1.1)



Fig 1.1

Note:

When requesting spare parts please state the serial number found on the serial number identification plate.

1.8 Main Machine Components

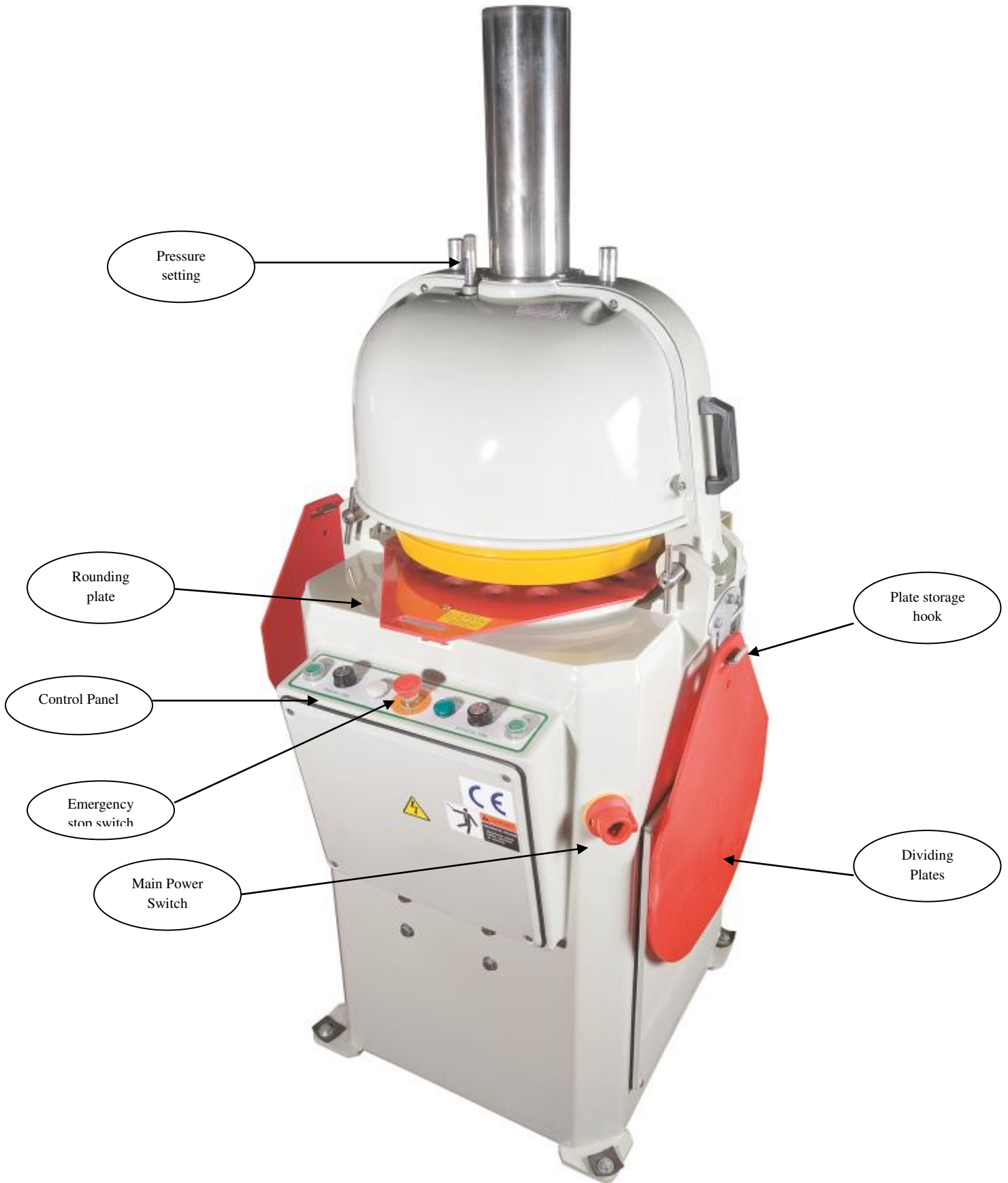

Fig1.2 Main Machine Components

1.9 Safeguards

This machine has been fitted with safeguards to ensure safe operation of this machine, in accordance please ensure the following;

- Do not place foreign objects in under the head of the machine.
- Ensure training in the safe operation of this machine is carried out with all operators.
- Do not wear loose clothing, ties, chains, or watches that could get caught into the moving parts of the machine.
- Ensure safeguards are in operable order before using the machine on a daily basis.
- Tampering with the safety devices creates hazards for the machine operator, for which International Bakery Equipment Pty Ltd or its agents will not be liable.

Note:

In the event that one or more of the safe guards do not operate or fail contact your supplier immediately. **DO NOT OPERATE THE MACHINE.**

Tampering with or modifying the machine will void warranty.

Emergency Stop Button.

The machine is equipped with a red emergency stop button located centre of the control panel and allows the operator to stop the machine in case of emergency see Fig 1.2

2. Transport and Installation:

2.1 Transport

The instructions given in this section must be carefully followed when transporting the machine. This operation may include but is not limited to the following:

- Storage of the machine
- Installation of the machine
- The machine comes supplied in a secure packing crate which needs to be handled with care to protect the machine.
- When being transported the machine crate should be secure to the transporting vehicle using approved tie down straps to avoid the machine tipping over.
- The machine should not be placed on top of other items during transport.
- When lifting the machine ensure all persons are at a safe distance.
- The forklift operator is to hold the appropriate qualifications.
- Do not climb on or place body under machine crate when it is being lifted from the ground or transport vehicle.
- When lifting the machine crate ensure forks are spread to the maximum width of the crate and the crate is against the cradle of the forklift (Fig2.1).



Fig 2.1

2.2 Installation

- Ensure transport crate and all protective packaging is removed.
- Carefully clean the machine using a damp clean cloth, removing dust on all surfaces.
- When the machine has been unpacked, check the condition of the machine. Any visible damage indicates that the machine has been dropped or hit by something during transport. This could lead to malfunctioning. If damage has occurred during transport it should be attributed to the carrier and International Bakery Equipment Pty Ltd or its agent should be informed immediately of the situation.
- Locate the divider in a level convenient position where the operation of the machine is safe and accessible and blot to the floor using the provided bolts.
- Before making the electrical connections check the specifications found in section 1.6 of this manual and ensure they match those of your electrical service.
- Make certain the electrical supply is correct and the correct breaker is in place to ensure protection from a short circuit.
- Ensure the three phase connection of the bun divider is correct and running in the right direction the direction of the arrow.
- A qualified person should correct electrical connection if required.
- Train all operators in the safe operation of this machine.

3. Machine Operation:

3.1 Intended Operation

This machine has been designed and manufactured for the safe dividing and rounding of dough's automatically with the use of a hydraulic system. With a dough range of 900g to 3600g divided into bread rolls then utilising an even balanced pressure plate and the dividing blades to ensure an even pressure and accurate dividing of the dough into 30 pieces of equal weight.

This machine has been designed and built to operate indoors.

3.2 Control Components

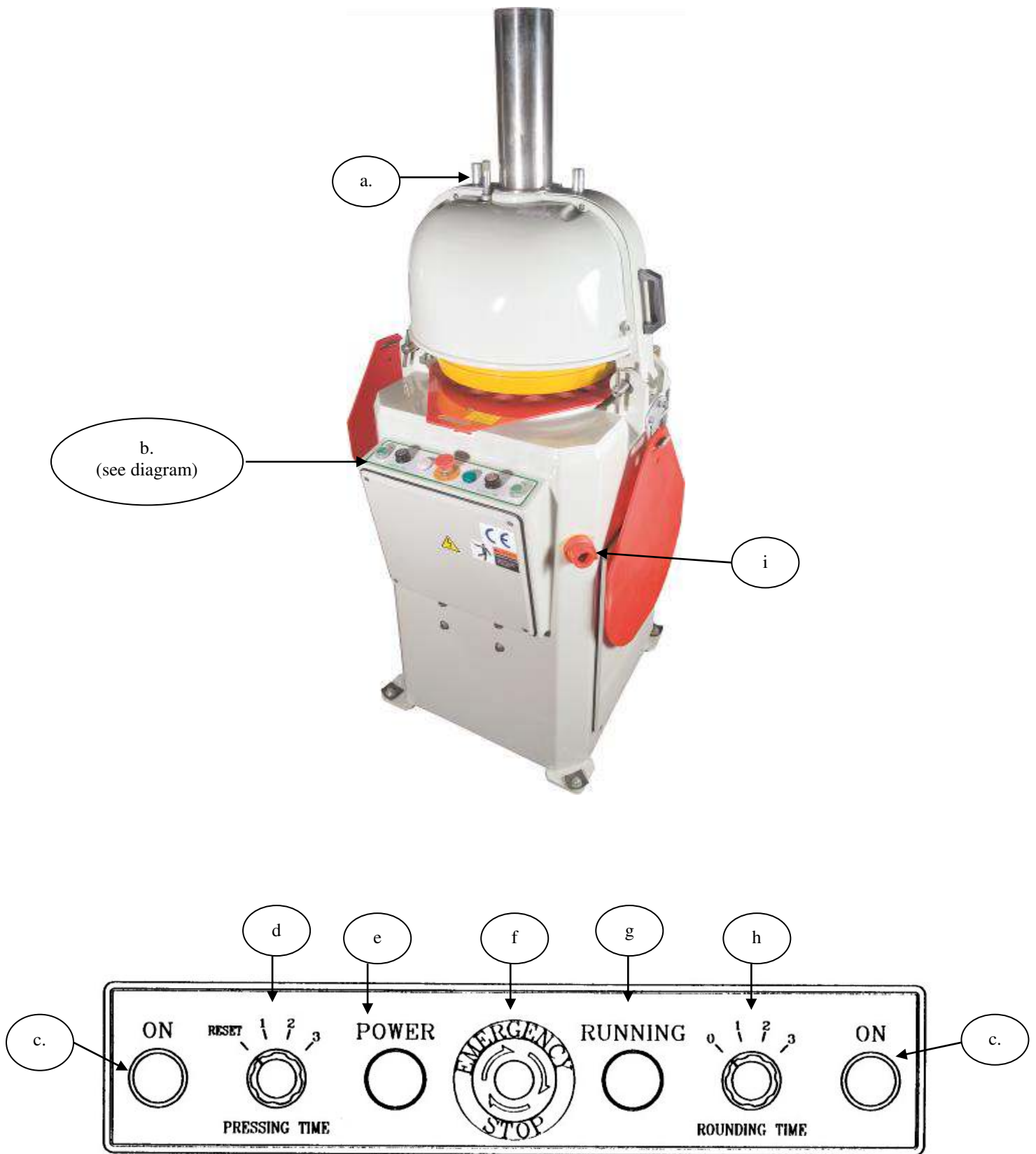

Fig 3.1 FABDR Control Components

Location	Description	Operation Performed
a	Weight adjustment screw	Weight adjustment for the size of the dough piece
b	Control panel	Control components of the machine
c	On buttons	Start the dividing /rounding process by pressing these two buttons at the same time.
d	Pressing time switch	Sets the desired pressing time
e	Power light	Will be lit when machine is turned on
f	Emergency stop button	When pressed it stops the machine completely.
g	Running light	Will be lit when machine is operating
h	Rounding time switch	Sets the desired rounding time.
i	On / Off Switch	Turns the power on and off to the machine.

3.3 Dividing Rounding Operation

These operating procedures are to be used as a guide, as every bakeries dough consistency is different.

These steps should be used to set up the FABDR to your specific product and by keeping records of the settings it will assist in the day to day operation of this machine, be aware though you may still need to fine tune the settings that you record as your dough can change i.e. longer than normal bench rest, or a slacker dough.

- Turn the power on using the on/off switch (i).
- Use the weight adjustment screw (a) to set pressure plate according to dough weight.
- Press dough piece out onto the dividing plate evenly to ½ of the outside circles and place into machine ensuring plate is flat and against back stops and pin is in the hole in the front of the plate.
- Set the desired pressing time using the pressing time switch (d).
- Set the desired rounding time using the rounding time switch (h).
- Push the two on buttons at the same time (c), if only one is pressed the machine will not operate.
- If the dough pieces come out and are torn less rounding time is needed, if they are not formed into the bread rolls properly longer rounding time is needed.

4. Cleaning & Maintenance:

4.1 Cleaning

- Always turn power off at the wall and unplug machine prior to any cleaning or maintenance procedures to be carried out.
- Keeping the machine cleaned helps to maintain the efficient hassle free operation of the machine.
- This machine should be cleaned at the end of every day, to prevent a build up of dough crumb and flour dust.
- Remove excess flour dust with a soft brush.
- Using a plastic scraper remove any dough remnants from dividing plate.
- Wipe over the entire machine with a damp cloth with a neutral detergent, (Harsh chemicals will damage the machine).

Note:

Do not use water jets or hoses to clean this machine as excess water can damage the machine, and the safe operation of the electrical components.

Note:

ONLY paraffin or white oil can be used to lubricate the dividing blades. The blades only need a very fine film of oil coating them and this can be done at the end of the cleaning process at the end of production daily.

4.2 Maintenance

It is recommended that this machine should be serviced once every 12 months by a qualified technician to maintain hassle free operation.

If in the event the machine does not operate correctly it is recommended that you contact your supplier to ensure a qualified technician services the machine for you.

It is not advisable to attempt any repairs without prior knowledge of the mechanical or electrical systems used in the manufacture of this machine, use only qualified technicians.

Note:

Any attempt to modify this machine in any way will result in the warranty being voided.

Tampering with the mechanical or electrical systems in this machine will void warranty.

4.3 Spare Parts List

No.	Description
101	Support plate
102	Support spring block
104	Support stand
105	Arch fixed stand
106	Extension spring
107	Flour frame
108	Back hood
109	Front hood
110	Stop knife
111	Extension spring
114	Down
119	Hanger
120	Connector
122	Connected rod
124	U-Block
126	Cover plate
127	Knife stand
129	Neck screw
133	Main shaft
135	Extension spring
136	Setting stand plate
137	Fish shape moving block
140	Revolving outer stand
141	Plug
142	Rounding tray

No.	Description
145	Transmission belt wheel
146	Motor belt wheel
147	Nut for revolving stand
148	Moving sheet
155	Pendulum stand
159	Axel of leaver stand
160	Up/down moving rod
167	Ball plug
173	Screw
174	Knife
175	Extension spring screw
180	Axle
181	Frame
182	Cross frame
183	Leading axle centre
185	Down moving bearing stand
186	Down part of machine
192	Fixed plate
194	Screws
196	Fixed plug
205	Oil cover plate
210	Top hood
310	Sleeve
313	Bearing stand sleeve
352	Electric box cap

Spare Parts List Continued

No.	Description
450	Hydraulic cylinder/up
455	Hydraulic cylinder
460	Fixed plate
468	Stop plate
469	Fixed rod/up
470	Support plate
471	Oil box

No.	Description
472	Oil box cap
M-1	Motor
BL-1	belt
B-1	Bearing
B-2	Bearing button body
B-3	bearing

4.4 Exploded Parts Drawing

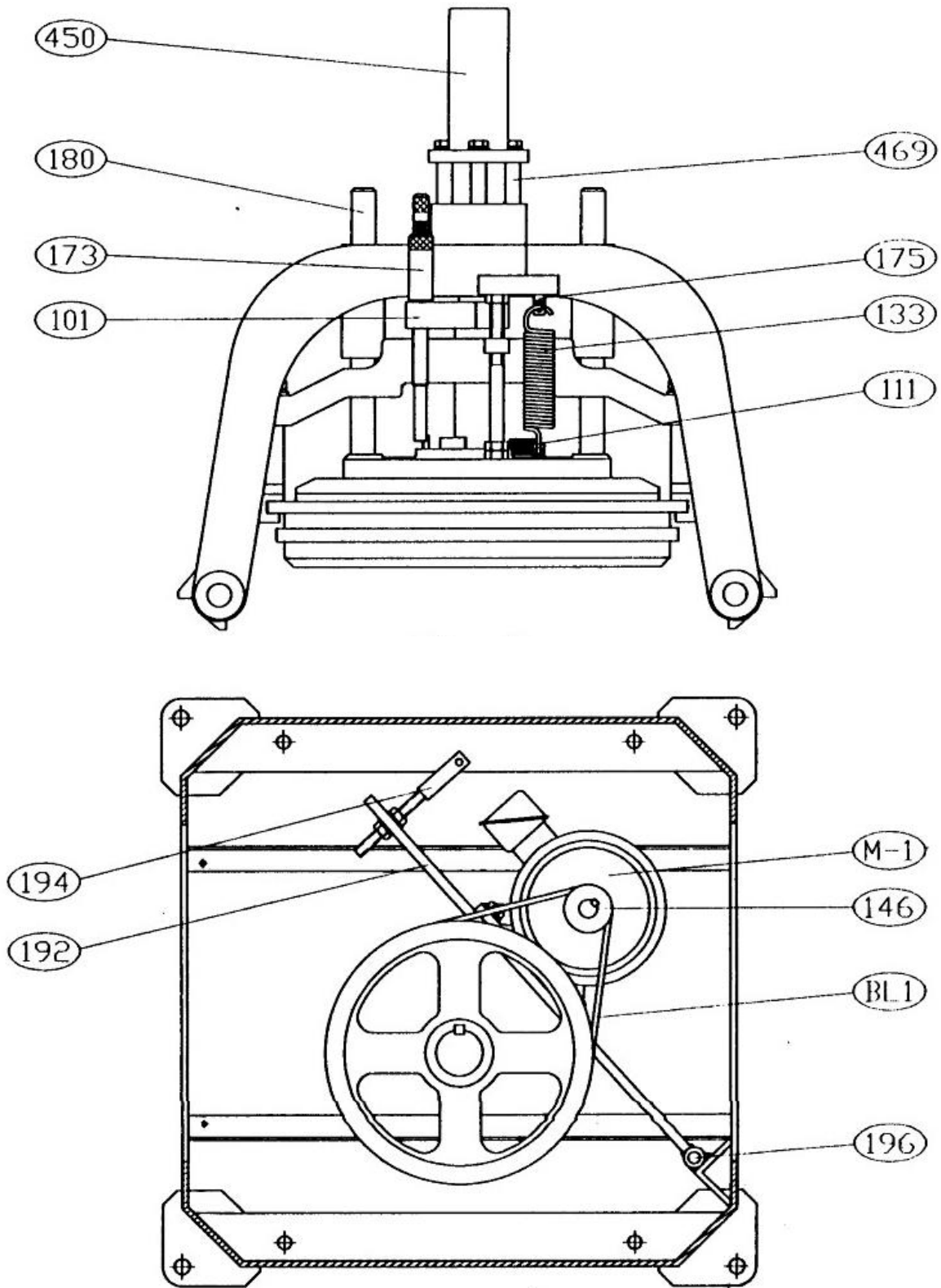

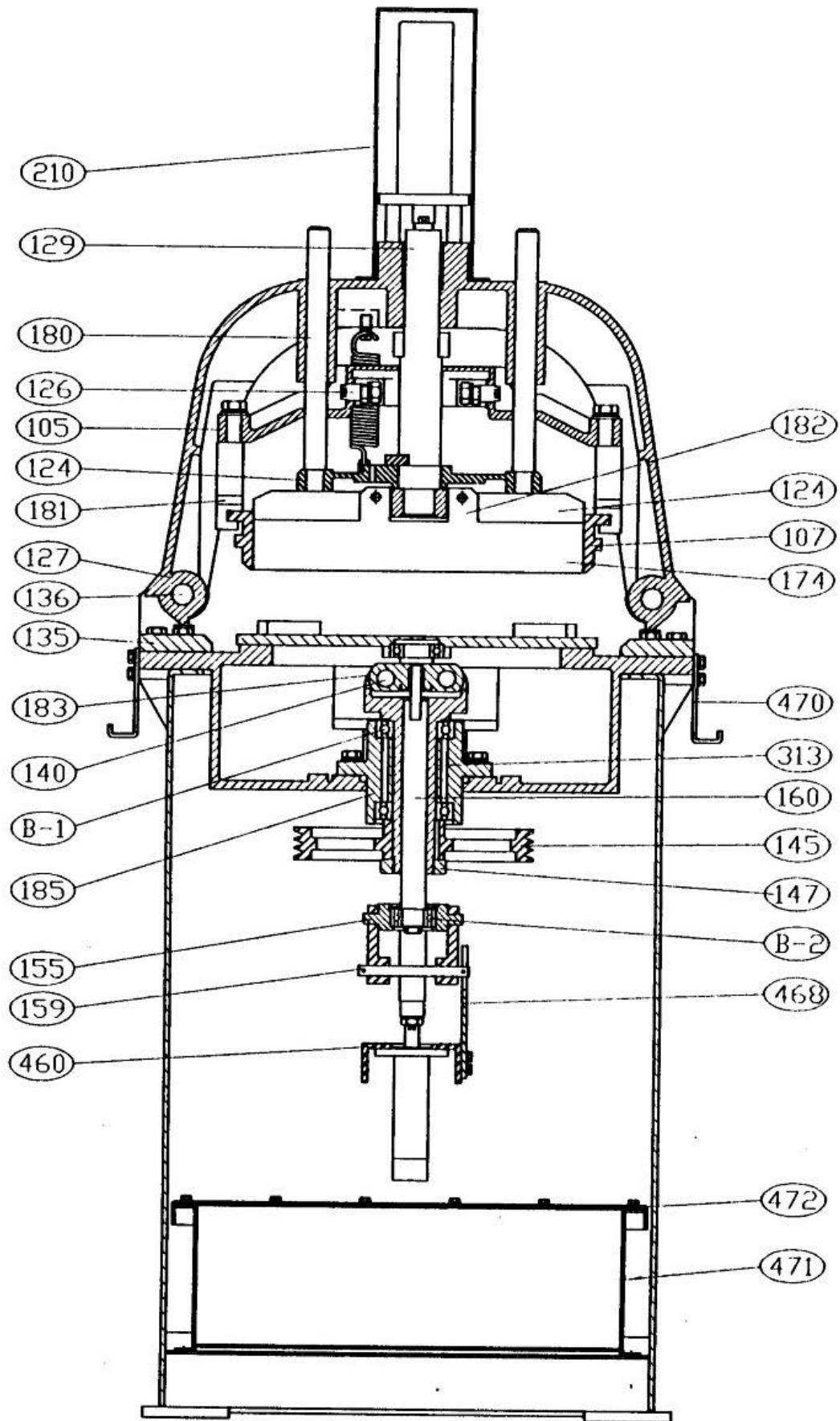

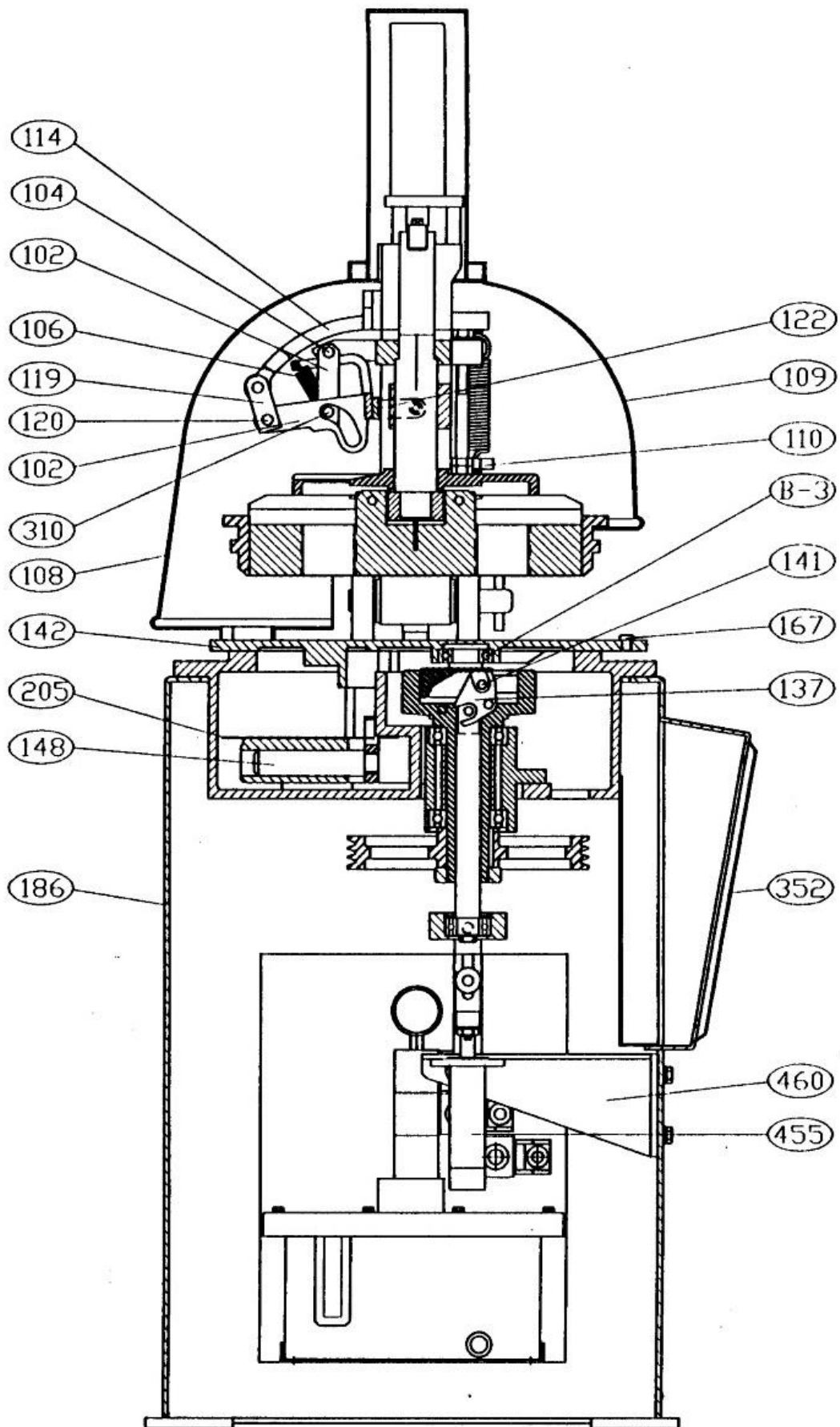

4.6 Hydraulic Control System

