

SIGMA

Bakery Pastry Pizza equipment

Via Artigianato 85 – 25030 Torbole Casaglia.
(BRESCIA) – ITALY – Tel 030 265 04 88 – Fax 030 265 01 43

INSTRUCTION, USE AND MAINTENANCE MANUAL SHEETER 500

Translation of the original instructions

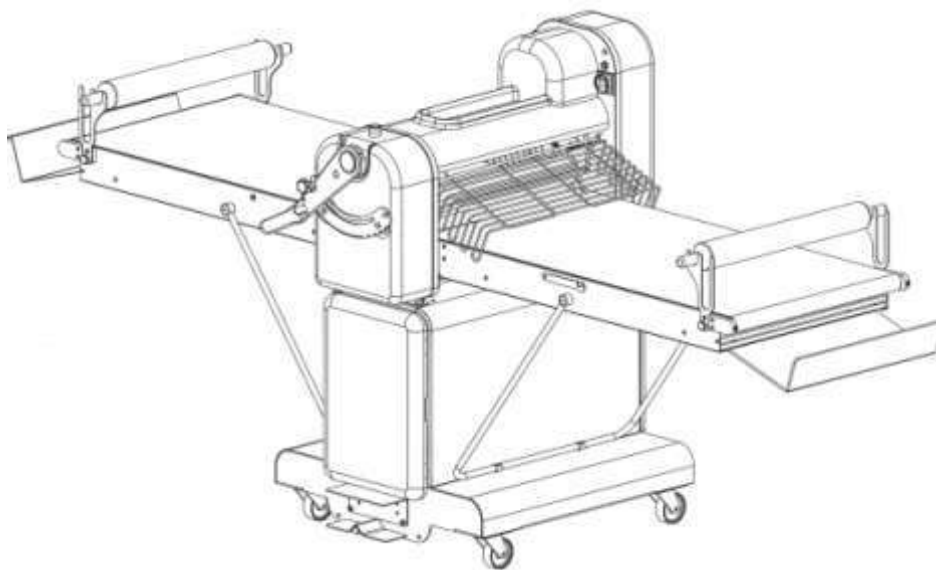
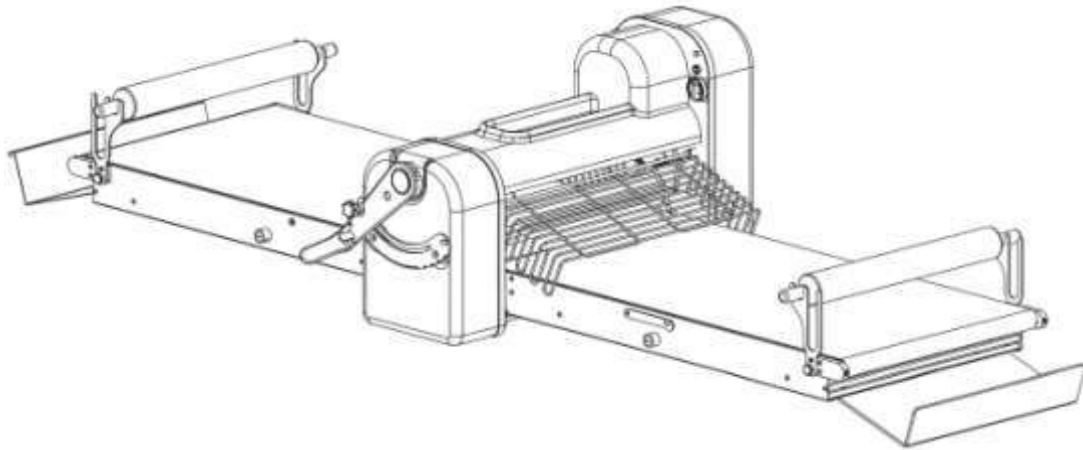

Edition date: 01/01/2015



1. General information	4
1.1. Preamble	4
2. Content of the declaration of conformity	5
3. Warranty terms	6
3.1. Validity	6
3.2. How to fulfil the warranty	6
3.3. Parts subject to wear	6
4. Main safety standards	7
4.1. Safety standards	7
4.2. Safety devices	7
4.3. Educating and training of machine operators	7
5. Responsibilities of the customer	9
5.1. How to order spare parts	9
6. Safe operating procedures	10
6.1. Risks for the operator	10
7. Layout and use of the manual	12
7.1. Glossary	12
8. Description of machine	13
9. Identification of the machine	15
9.1. Main components	15
10. Technical data and features	16
10.1. Unit of measurement	16
10.2. Technical data, dimensions, packaging and lifting	16
10.2.1. Technical data	16
10.2.2. Dimensions	16
10.2.3. Packaging	17
10.3. Control panel and master switch	18
10.4. Types of drive, motors and actuators	18
10.5. Machine storage and preservation	18
10.5.1. STORAGE	18
10.5.2. Machine storage	19
10.6. Type and features of the product and materials used	19
10.7. Type and nature of the machine's emissions	19
11. Transport and installation	20
11.1.1. Machine on pallet	20
11.1.2. Machine without pallet	20
11.2. Description of commissioning and initial start-up	21
11.2.1. Installation	21
11.2.2. Connection to electrical mains	21
12. Safety devices adopted	22
12.1. Alarms and warning signals	22
13. Instructions on use	23
13.1. Notes on use	23
13.1.1. Assembly instructions for the rod wipers	23
13.1.2. Instruction for the protection grid	23
13.1.3. Inserting the belts	24
13.2. Machine operation	25
13.2.1. First start-up	25
13.3. Operation	26
13.3.1. Operational functioning	26
13.3.2. End of work	27



14. Replacements and/or scheduled maintenance	28
14.1. Master switch	28
14.2. Stop circuit and safety micro switch of the grid	28
14.3. System checks	29
14.4. Routine maintenance	29
14.5. Replacing the belt and the belts' bearings	30
14.6. Protection grid change	34
14.7. Disassembly and cleaning of rod wipers	35
14.8. Extraordinary maintenance	37
14.9. Daily maintenance	37
15. Troubleshooting	38
15.1. Blockage of machinery and necessary remedies	38
16. Exploded view of machine	39
17. Recommended spare parts	53
17.1. Recommended spare parts - electrical parts	53
17.2. Recommended spare parts for belts	53
18. Wiring diagram	54
19. Demolition and disposal	57
19.1. Obligations of informing users	57

1. General information

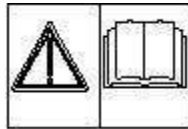

This instruction, use and maintenance manual provides the instructions necessary for transportation, commissioning, use and maintenance of the machine. It must be consulted before any one of these manoeuvres.

The manual must be read not only by maintenance technicians, but also by operators in charge of the machine who must correctly carry out what is within their line of competence.

The manual is an integral part of the machine. It must be kept in a suitable place where it can remain intact and where it can be consulted during the whole life of the machine.

In case of loss or deterioration, request a copy from the manufacturer, clearly specifying all of the machine identification data (year of manufacture, model, serial number).

All references and/or instructions in this manual relating to:

- CE marking;
- CE declaration of conformity;
- declaration of incorporation of the partly-completed machine;
- directives and regulations issued by the EU institutional bodies (Parliament, Council, Commission, etc.) and related transposition deed of the EU member states;
- European harmonised standards,

are to be considered valid only for the machines intended to be placed on the EU market or for which compliance with Laws, Directives, etc. issued by the EU was expressly required by the customer and formally accepted by SIGMA SRL.

These references and instructions have no meaning and value for all machines not intended for the EU market, apart from the above exceptions.

1.1. Preamble

This manual is intended to help the people entrusted with installation, use and maintenance of the machinery to make the most of the product features.

This manual must be kept and stay with the machine in the event of any moves, including when the machine changes hands. The manual must be kept available for reference in the interest of safe operation

The Manufacturer reserves the right to make changes to the product without notice.



The Manual is the property of the Manufacturer and it is prohibited to copy, modify or distribute the Manual without the Manufacturer's authorisation.

The following symbols are used to draw attention to certain points:

QUALIFICATIONS OF THE PERSONNEL: symbols used to indicate the specific skill needed for the intervention described (described in greater detail in the GLOSSARY).



ATTENTION: indicates hazardous situations that require special care



2. Content of the declaration of conformity

The undersigned manufacturer:

SIGMA SRL
VIA ARTIGIANATO, 85
25030 TORBOLE CASAGLIA (Bs), Italy
VAT No.: 03121980175

Through Ms. Ornella Salvadori, as Chairwoman;

DECLARES

that the machine: SHEETER 500

Year of manufacture:

complies with the relevant provisions provided by:

- Directive 2006/42/EC of the European Parliament and of the Council of 17 May 2006 on machinery and amending Directive 95/16/EC (transposed by the Italian state with L.D. 27/11/2010, no.17);
- Directive 2004/108/EC of the European Parliament and of the Council of 15 December 2004 on the approximation of the laws of the Member States relating to electromagnetic compatibility and repealing Directive 89/336/EEC;
- Regulation (EC) No. 1935/2004 of the European Parliament and of the Council of 27 October 2004 on materials and articles intended to come into contact with food and repealing Directives 80/590/EEC and 89/109/EEC
- Commission Regulation (EU) No. 1183/2012 of 30 November 2012 amending and correcting Regulation (EU) No 10/2011 on plastic materials and articles intended to come into contact with food;
- Commission Regulation (EC) No. 2023/2006 of 22 December 2006 on good manufacturing practice for materials and articles intended to come into contact with food;
- Ministerial Decree of Health No. 76 of 18 April 2007, regulation on the hygiene control of materials and objects of aluminium and aluminium alloys intended to come into contact with food;

The Chairwoman
Ornella Salvadori



3. Warranty terms

3.1. Validity

The warranty starts from the delivery date and lasts 12 months, if

- The machine was not damaged during transportation, and it was installed, commissioned, used and serviced as prescribed in this manual.
- It was not tampered with, modified and no unintended tools were installed on it.
- It did not undergo modifications or repairs carried out by the customer or third parties in a non-compliant fashion or without the prior consent of the supplier.

The following conditions constitute improper use of the machine:

- Loading more than what is allowed or use of unsuitable ingredients.
- Cleaning with unsuitable tools or instruments that can scratch the bowl or damage the machine, paint and plastic parts.
- Use of the machine in unsuitable places.

3.2. How to fulfil the warranty

If the customer finds defects in the machine, he must immediately inform the supplier, who will carry out a quick analysis of the lack of compliance and will establish the intervention mode with the customer.

After agreement with the supplier, the customer must provide him with the needed time and opportunity to carry out modifications, improvements, repairs or the supply of spare parts which the supplier deems reasonably necessary. If this does not occur, the supplier will not be held liable.

3.3. Parts subject to wear

Some components are scaled for a life duration far longer than that of normal use of the machine during the time of its warranty. Breakage or malfunctioning of these pieces depends on their use. They are therefore considered parts subject to wear and are not included in the warranty, unless they manifest evident defects in the parts or machinery.

Parts subject to wear: transmission belts, chain and bearings.



4. Main safety standards

The safe and systematic use of the machine is subject to compliance with the behaviour and standards listed hereafter.

4.1. Safety standards.

- Personnel must be in good physical and mental conditions and be adequately instructed on the use of the SHEETER by having read this publication.
- Only professional use of the machine is allowed in places where access to the public, to profane, to children and to anyone not expressly authorised is forbidden.
- It is forbidden to use the machine: for operations and / or with different product(s) to those specified; if the connections to the service facilities from the site are not run as expected in this manual; in places with risk of fire and / or explosion and major incidents, high humidity or wet, excess water vapour, oily vapour, dust, presence of corrosive substances / gases, adverse weather conditions; in the vicinity of naked flame, zones with projection of sparks and heat sources; in conditions of abnormal vibration or shock.
- The safety officer, and / or the employer, and / or the owner of the company, in choosing the person who will be authorised to use the machine (suitable person to work according to applicable laws), must check the same on the basis of attitudes and skills encountered and provide training of the same, with the reading of this publication, in order to provide comprehensive knowledge of the machine and of the rules of conduct applicable to it.
- The area around the machine must be well lit, free from other objects and clean. Leave about 250mm of free space around the machine, especially on the side where the master switch is located, leave 1000mm.
- The personnel in charge of running, cleaning and carrying out maintenance on the machine must wear the required P.P.E. (personal protective equipment): gloves, shoes with reinforced tip, goggles, masks and helmet.
- Do not wear dangling clothing or with fluttering hems (ties, torn suits, open jackets etc.) to avoid getting entangled.
- During maintenance and cleaning, the operator must release the master switch (IOFF) and place the system in safe conditions (for example, removing the plug and leaving it in a clearly visible position).
- Never leave the mixer unattended while it is running. Be careful of abnormal noises or behaviour. Keep away from rotating parts. Never open the guard unless the tool has completely stopped.
- In order to empty the machine completely, release the master switch (OFF), disconnect power by removing the plug and leaving it clearly visible, secure it and clean with water.

4.2. Safety devices.

The machine is equipped with some devices which protect its operation as well as the safety of the operator. They must not be removed or modified. Their operation must be checked periodically.

- Main switch: cuts power from the machine, for maintenance in safe conditions.
- Circuit breaker: interrupts power supply in case of overheating of the electric motor moving the spiral.
- Fixed guards: all casings and guards fixed with screws or mechanical locks can be removed only for maintenance, by specialised personnel and in the prescribed ways. When the work is finished, they must be reassembled immediately.
- Mobile guards: correctly closed mobile guards allow the machine to be used.

The lack of these conditions prevents the machine from working.

4.3. Educating and training of machine operators

As repeatedly stated in this manual, the employer must provide workers with adequate information and training, also practical (training), on the correct and safe use of the machine (must be simple and understandable in relation to the acumen that can reasonably be expected by those concerned).

The following table provides a minimum list of topics to be covered as information, training and educating of personnel; for clarity we provide the following definitions:



information: transfer of information, knowledge, etc..., without verification of learning;

training: transfer of information, knowledge, etc ..., on special and specific topics, with verification of understanding of the topics covered, but without practical demonstration;

training: transfer of information, knowledge, etc ..., with practical demonstration of their implementing on special and specific topics, and verification of understanding by application to practical cases of the topics

Topics	Information	Educating	Training	Chapter
Hazard characterising the machine and related risks. Use of PPE. Machine limits and destination. Intended and/or prohibited uses.	X	X	X	4
Safe operating method and procedures	X	X		6
Safety signs	X	X		6.1
Layout and use of the manual	X	X		7
Description of the machine	X			8
Control panel description	X	X		10.3
Machine storage and preservation	X			10.4
Noise emitted by the machine	X			10.7
Machine handling and transportation	X		X	11.1
Description of commissioning and initial start-up	X	X		11.2
Safety devices adopted	X	X	X	12
Instructions on use	X	X	X	13
Replacements and/or scheduled maintenance (routine and extraordinary maintenance)		X	X	14
Cleaning of the machine		X	X	14
Troubleshooting	X			15



5. Responsibilities of the customer

The environmental conditions of the place where the machine is installed must meet the following requirements:

- Free of humidity.
- Away from sources of heat and water.
- Suitable ventilation and lighting according to the health and safety regulations in force. The floor must be flat and compact and, therefore, easy to clean properly.
- Do not place in the immediate vicinity of the machine, obstacles of any nature that may affect the normal operation and ventilation of the machine in question (leave about 250 mm free around the machine, especially on the side, where the master switch is located, leave 1000mm).
- Upon machine arrival, ensure it is intact. Any damages incurred during transport or delivery must be immediately reported.
- Ensure that the power supply matches that of the machine: check the plate on the machine and on the wiring diagram (chap. 18). Connection to the line **MUST** be made through a socket blocked under EC standard, equipped with set of three valves adapted to the amount of current consumed during machine operation.



An automatic circuit breaker compatible with the machine, and with a minimum contact opening distance of 3 mm, must be installed on the power line. In particular, an earthing system according to the regulations in force is essential.



Make sure that the voltage supply and frequency of the system are compatible with the values in the technical features and the plate on the machine.

5.1. How to order spare parts

SIGMA S.r.l. reserves the right to carry out all the modifications that it deems necessary for its machine models.

It is therefore always necessary to specify:

- Type of machine
- Year of construction
- Position
- Description
- Serial no.
- Required number of parts.

Send the request to:

Sigma S.r.l.

Via Artigianato 85,

25030 Torbole Casaglia (BS)

Tel 030 265 04 88- Fax 030 265 01 43

www.sigmasrl.info - E-mail: info@sigmasrl.info

6. Safe operating procedures



READ THESE INSTRUCTIONS WITH CARE BEFORE USING THE MACHINE

The following safety requirements must be observed in order to avoid hazards and/or physical injury due to electrical current, mechanical components, fire, hygiene:

- Keep the workplace neat and tidy. Clutter can cause accidents.
- Assess the environmental conditions. Do not use or leave the machine in a wet, damp or poorly lit environment, or in the vicinity of flammable liquids or gases.
- Keep children and unauthorised personnel away. Do not allow these people to approach the machines or work station.
- Use the machine within its operating range and for the purpose for which it was designed. It works best and at its safest when it is not overloaded.
- Wear appropriate clothing. Do not wear loose-fitting clothing or accessories which may become caught in the moving parts of the machine. Use the shoes with reinforced tip and non-slip sole. For hygiene as well as safety reasons, wear gloves and use a specific hair net for long hair.
- Protect the power cable. Do not pull the cable to remove the plug from the socket. Do not expose the cable to extreme heat, sharp edges, water or solvents.
- Avoid unstable positions. Find the most suitable position that ensures absolute stability.
- Always exercise extreme caution.
- Always take the plug out of the socket after use and before cleaning and maintenance and before moving the machine, and leave it in a clearly visible place.
- Never use extension cables outdoors.
- Make sure that the machine is not damaged. Before using the machine, carefully make sure that all the safety devices work properly. Make sure that: the mobile parts are locked in place, there are no damaged components, all the parts have been assembled correctly and the machine can be run normally in optimal conditions. (See chapter 14)
- Entrust repairs to qualified personnel. All repairs must be carried out by qualified people using original spare parts.

FAILURE TO OBSERVE THESE REQUIREMENTS CAN PUT THE USER'S SAFETY AT RISK.

6.1. Risks for the operator



Danger for limbs: it is possible to access the moving parts of the machine from the slide or removing the casing during maintenance.



They are dangerous areas where serious physical injuries can occur. Do not insert limbs or other objects without having put the machine in safe conditions.



Risk of electrocution: the machine must not operate without an adequate earthing system. It must be connected to a system built in compliance with the construction standards in force in the country where it is installed.

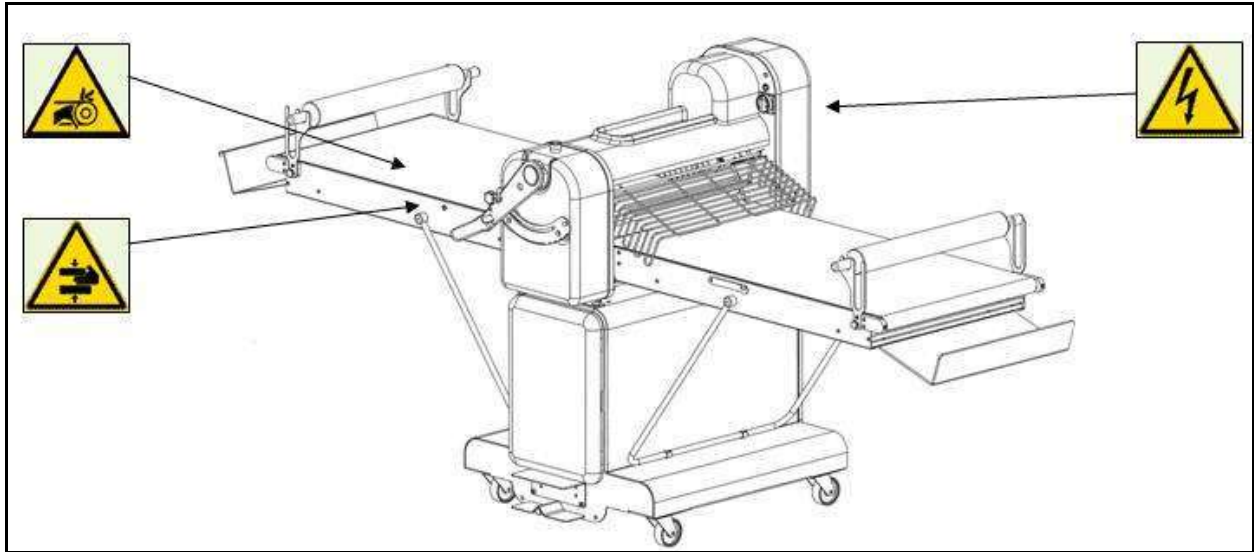

Obligation to carry out earthing.



Prohibition to clean and lubricate moving parts



Prohibition to remove the safety devices and guards

ATTENTION!

Wear the provided PPE during operation (e.g. shoes with reinforced tip and gloves).

Clean the machine thoroughly after use.

Do not remove the safety devices or protective casings.







Do not introduce any objects with the parts in motion.

Before any manoeuvre wait for the machine to completely stop, turn it off and disconnect it from the mains.

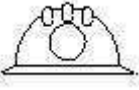

7. Layout and use of the manual

7.1. Glossary

Symbol	Description	Features
	OPERATOR	Person acquainted with operating, adjusting and programming the machine and its protection and safety systems, who knows possible work cycles and ingredients to be used with relative maximum admitted amounts and who has read and understood the use and maintenance manual.
	ELECTRICAL MAINTENANCE TECHNICIAN	Person in good health who, due to qualification, job or experience, is qualified to carry out the profession of electrical maintenance technician and who has read and understood the use and maintenance manual.
	MECHANICAL MAINTENANCE TECHNICIAN	Person in good health who, due to qualification, job or experience, is qualified to carry out the profession of mechanical maintenance technician and who has read and understood the use and maintenance manual.
	HANDLING OPERATOR	Person in good health who, due to qualification, job or experience, is qualified to carry out handling of loads and who has read and understood the use and maintenance manual.
	ASSISTANCE Tel.+39030.265.04.88 Fax+39030.265.10.82 www.sigmasrl.info Email: info@sigmasrl.info	Requesting manual updates. Phone customer assistance concerning operation, starting or faults of the machinery. Requesting spare parts, repairs, system overhauls, interventions on site. Training courses.
	ATTENTION	This sign requests you to pay particular attention to the operations indicated. Lack of compliance can cause harm to personnel or damage to the machine.

8. Description of machine

USE AND DESCRIPTION OF THE MACHINE:

The SFG sheeters are machines designed for professional use only, for catering, pastry and gastronomy laboratories for the preparation of food. Their task is to roll layers of dough with butter, margarine or eggs (special version) in order to obtain sheets of the desired thickness. The function of gradually thinning the compound is performed by a pair of rollers whose opening is adjustable until the finished product is obtained. The belts arranged at the sides of the rollers drag the dough, one feeds the rollers, the other evacuates the material thinned by the same. Since the thinned material is longer than that to be rolled, the drive speed of the evacuation roller is greater than that of power supply. Since the rolled dough is once on the right belt and once on the left one, the motion must be reverse at each passage and obviously the relative speeds of the belts are automatically reversed. The dragging direction is chosen by the operator using a lever or a pedal, depending on the version of the chosen machine; the dough is gradually thinned by a lever engaged by a toothed crack which keeps it in the desired position. When the dough becomes so long to no longer fit on the belt, it can be dropped on the appropriate trays or wrapped on rolling pins placed at the end of the rollers.

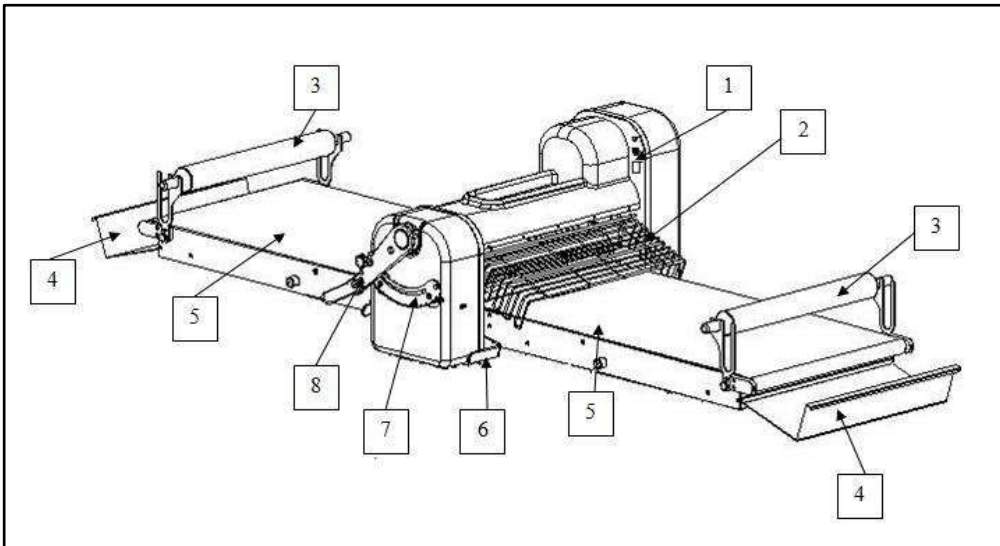

SHEETER SFG 500 B

- 1) MASTER SWITCH AND MAINS LIGHT
- 2) PROTECTION GRID
- 3) WOOD ROLLING PIN
- 4) PASTA COLLECTOR SHEET METAL
- 5) BELTS
- 6) ROLLERS DIRECTION EXCHANGE KNOB
- 7) GRADUATED SECTOR
- 8) THICKNESS HANDLE

SHEETER SFG 500 B

- 1) MASTER SWITCH AND MAINS LIGHT
- 2) PROTECTION GRID
- 3) WOOD ROLLING PIN
- 4) PASTA COLLECTOR SHEET METAL
- 5) BELTS
- 6) ROLLERS DIRECTION EXCHANGE KNOB
- 7) GRADUATED SECTOR
- 8) THICKNESS HANDLE

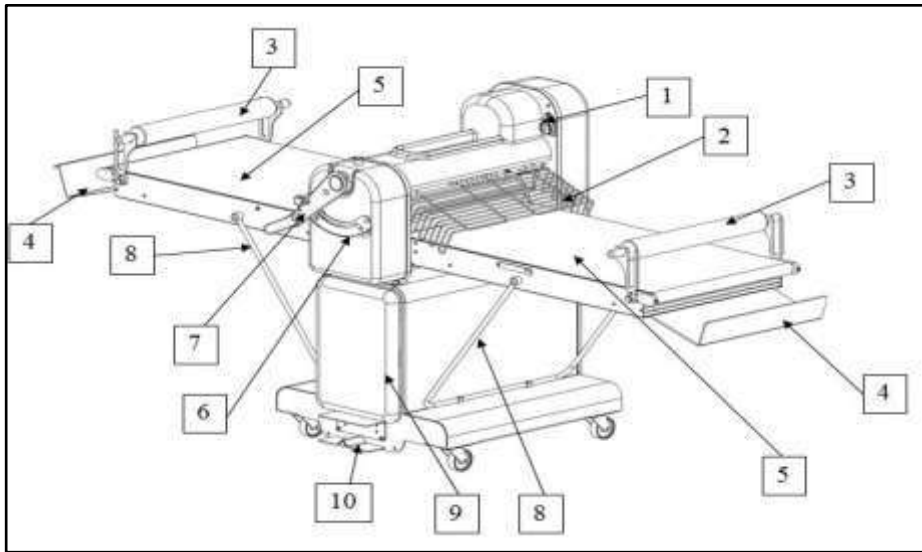

SHEETER SFG 500T - 500TM

- 1) MASTER SWITCH AND MAINS LIGHT
- 2) PROTECTION GRID
- 3) WOOD ROLLING PIN
- 4) PASTA COLLECTOR SHEET METAL
- 5) BELTS
- 6) GRADUATED SECTOR
- 7) THICKNESS HANDLE
- 8) BELTS SUPPORT
- 9) BASE
- 10) ROLLERS DIRECTION EXCHANGE PEDAL

10. Technical data and features

10.1. Unit of measurement

The units of measurement used in the manual are:

- Millimetres [mm]
- Kilograms [kg]
- Kilowatts [kW]

10.2. Technical data, dimensions, packaging and lifting.

10.2.1. Technical data

MODEL	MACHINE MASS [kg]	POWER [kW]	CONSUMPTION [kW]	BELT DIMENSION S [mm]	POWER SUPPLY
SFG 500 B	142	0.55	0.55	500x700	400V 50Hz 3 phases + PE
SFG 500 T	170	0.55	0.55	500x700	400V 50Hz 3 phases + PE
SFG 500 TM	185	0.55	0.55	500x1180	400V 50Hz 3 phases + PE

10.2.2. Dimensions

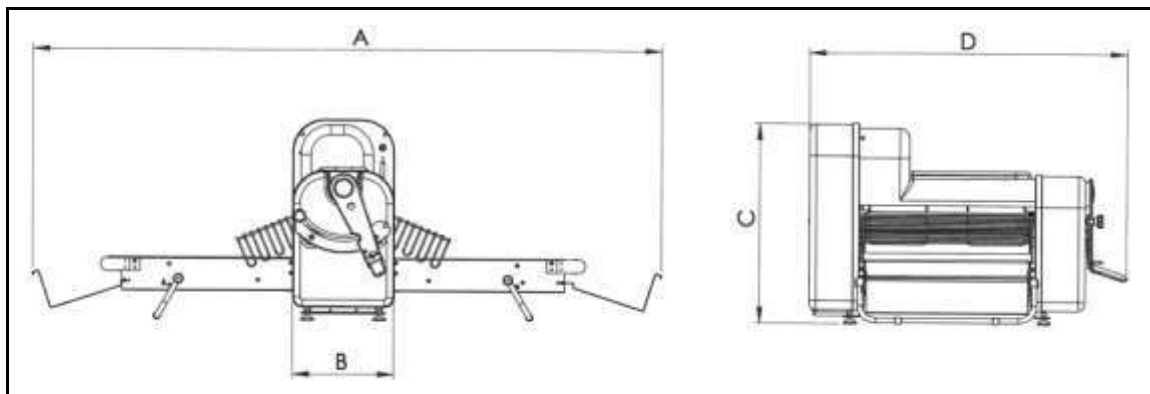

Sheeters 500 B

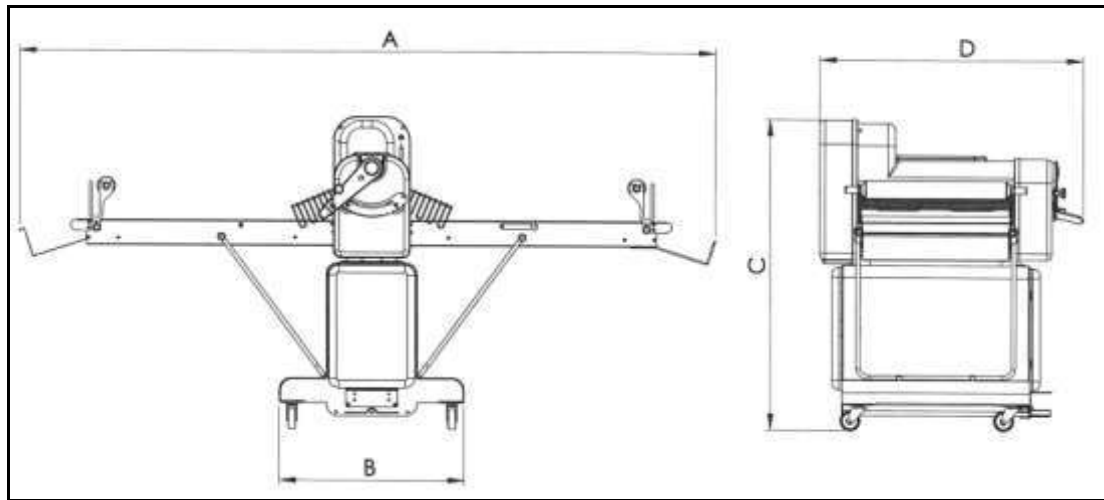

Sheeters 500 T - 500 TM

MODEL	A	B	C	D
SFG 500 B	1920	310	612	975
SFG 500 T	2035	750	1270	1000
SFG 500 TM	2990	750	1270	1000

10.2.3. Packaging

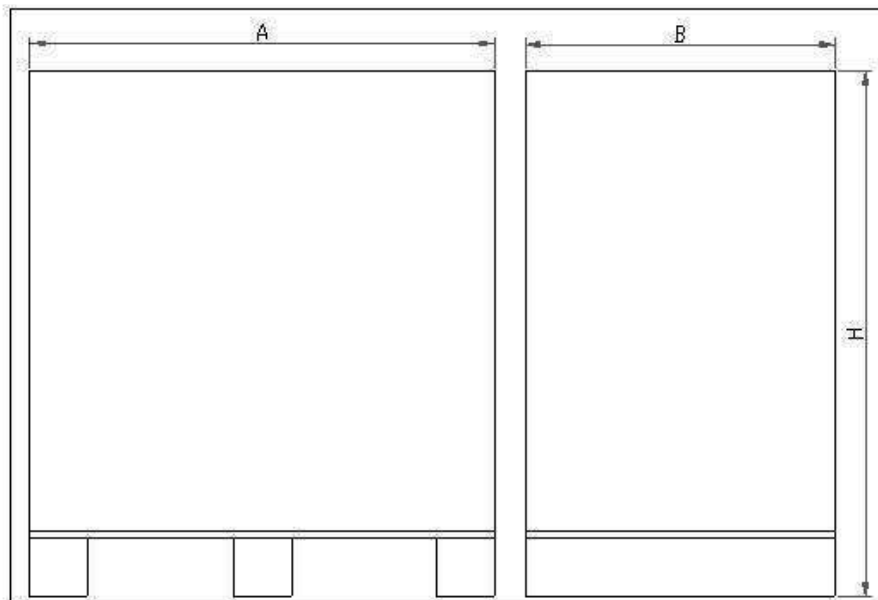

MODEL	A	B	H
SFG 500 B	1240	820	750
SFG 500 T -500 TM	1340	850	1450

10.3. Control panel and master switch

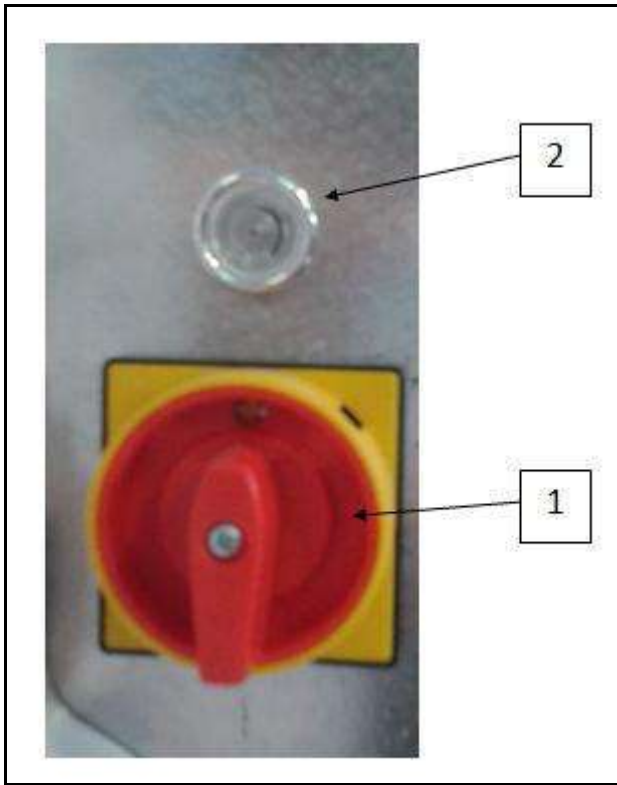

- 1) MAIN SWITCH
- 2) LUMINOUS LED

10.4. Types of drive, motors and actuators.

TYPE OF DRIVE: MECHANICAL

T71 MOTOR: 0.55kW 1.5A 230-400V/1-3/50

10.5. Machine storage and preservation

10.5.1. STORAGE

Storage of packaged machine:

The machine must be stored in a closed and covered place, on a smooth, solid surface protected from dust and dirt, sheltered from atmospheric agents and in a hygienically safe location.

The temperature must remain between 4 and 40°C, and humidity no greater than 90%.

Storage of unpackaged machine.

If the machine has already been unpackaged, in addition to the above, it must be lifted from the ground with a pallet or other and covered in order to protect it from humidity, dust and dirt. If wrapped in cellophane or another type of plastic, avoid airtight closing under the machine in order to prevent corrosion linked to condensate.



ATTENTION

The machine must not be stored outdoors.



10.5.2. Machine storage

Storage before a long period out of service:

- Clean the machine thoroughly.
- Disconnect it from the electrical mains.
- If possible, put it back into its original packaging.

10.6. Type and features of the product and materials used

CONDITIONS FOR USE:

- The machine needs to be installed inside of a lit, ventilated building, on a solid, level support. Temperatures from 5 to 40°C with humidity no greater than 90%.
- Lighting: the light available to the operator must comply with the type of work carried out, in relation to general lighting, according to the Standards in force. It must, in any case, be sufficient to read the controls and danger signs and must not blind the operator.

10.7. Type and nature of the machine's emissions

- Vibrations: in correct working conditions, vibrations do not create dangerous situations.
- Noise emissions: 70 dbA for normal use.

11. Transport and installation

11.1.1. Machine on pallet



Make sure that the lifting equipment capacity is adequate to the load.

Widen the lifting forks as much as possible and make sure they stick out from the pallet.

Work in an area free from persons and animals.

During movement, always keep the load as close to the ground as possible.

Use the required P.P.E. (e.g. shoes with reinforced tip).

Instructions on lifting with a forklift: always use a pallet when moving the machine.

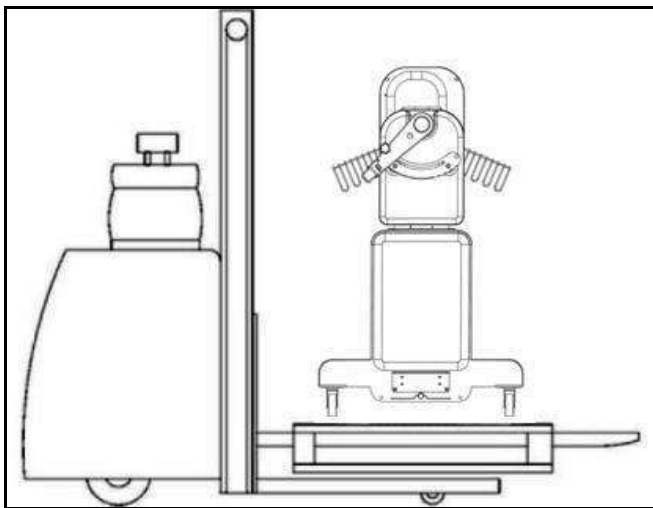

SFG 500 T - 500 TM

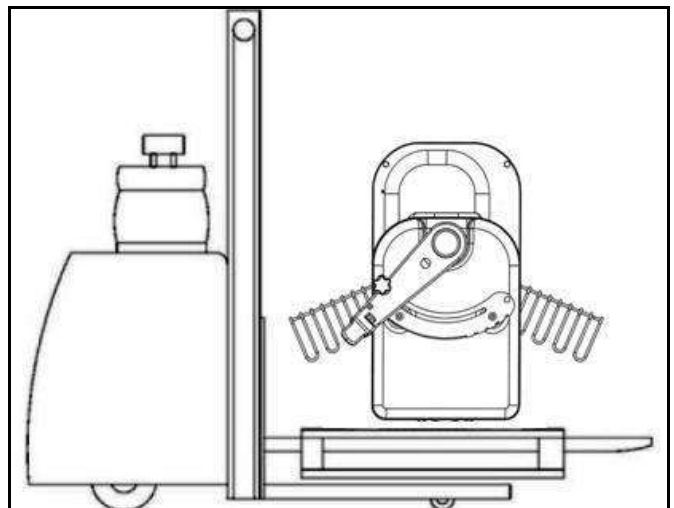

SFG 500 B

11.1.2. Machine without pallet.



To remove the machine from the pallet, lift it as shown in the following figure, using an adequately sturdy strap.

Make sure the lifting equipment is adequate for the load. Work in an empty area. During movement, always keep the load as close to the ground as possible.

Use the required P.P.E. (e.g. shoes with reinforced tip and non-slip sole, gloves and helmet).

During lifting the machine may be slightly tilted.

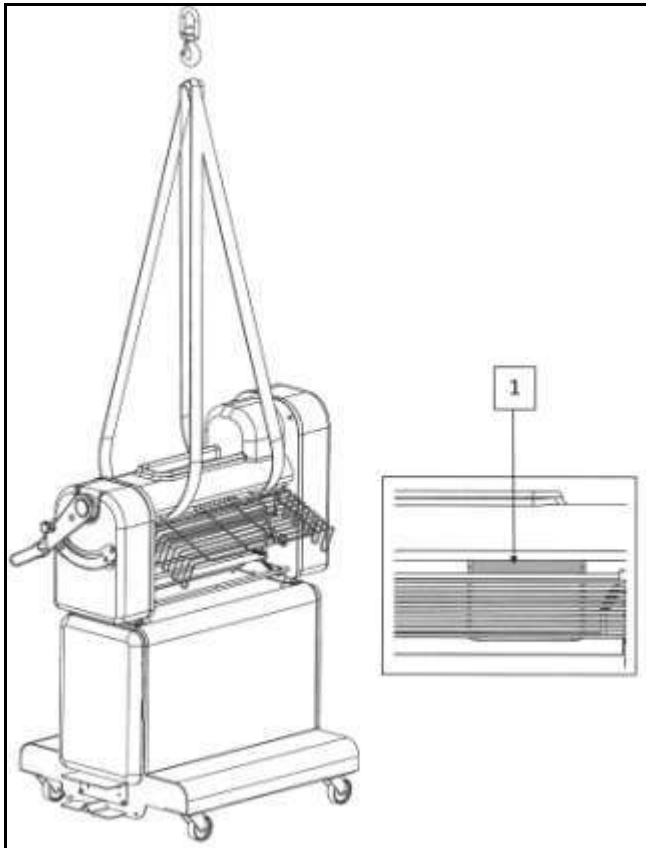

1) Insert the belts.

11.2. Description of commissioning and initial start-up

11.2.1. Installation



The machine with base must be rested on the ground. Two wheels with specific locking pedal to hold it in position. The machine without base must be rested on a table or stand, adequate sturdy and stable.

The mixer must rest on a smooth surface, sufficiently sturdy for the load (floor with resistance over 20 kgcm²). The walls and the floor must be in good condition and easy to clean.

If the floor is uneven, align the machine before connecting it to the mains.

11.2.2. Connection to electrical mains



The electrical connection must be carried out by a specialised electrician, according to the methods and standards in force in the country where it is installed.

A power supply line with wire section of at least 1.5 mm² with socket with locked plug and switch must be installed near the machine



Make sure that the voltage and frequency of the system are the same as those on the machine identification plate. Incorrect connection voids the warranty.

12. Safety devices adopted

The device used for this machine is: PROTECTION GRIDS AND EMERGENCY BUTTON.

12.1. Alarms and warning signals

The alarm and warning devices on the machine in question are:

- MICRO "PIZZATO"



Base micro



Grid micro

13. Instructions on use

13.1. Notes on use



DO NOT REMOVE OR TAMPER WITH THE ELECTRICAL OR MECHANICAL GUARDS OR SAFETY DEVICES ON THE MACHINE.

MOVE YOUR HANDS AWAY FROM THE BELT BEFORE STARTING THE MACHINE, DURING TESTS AND DURING MACHINE USE

To work, the machine requires the grids closed and the belts fitted and in horizontal position, otherwise the safety systems prevent its operation

13.1.1. Assembly instructions for the rod wipers

Upon delivery, the rod wipers are already fitted in their seats. All rod wipers can be mounted in any position and to remove them from their seats for cleaning operations, proceed as follows:

release the rod wiper from the contrast spring (B);

press on the spring (A) and release the rod wiper from the opposite seat.

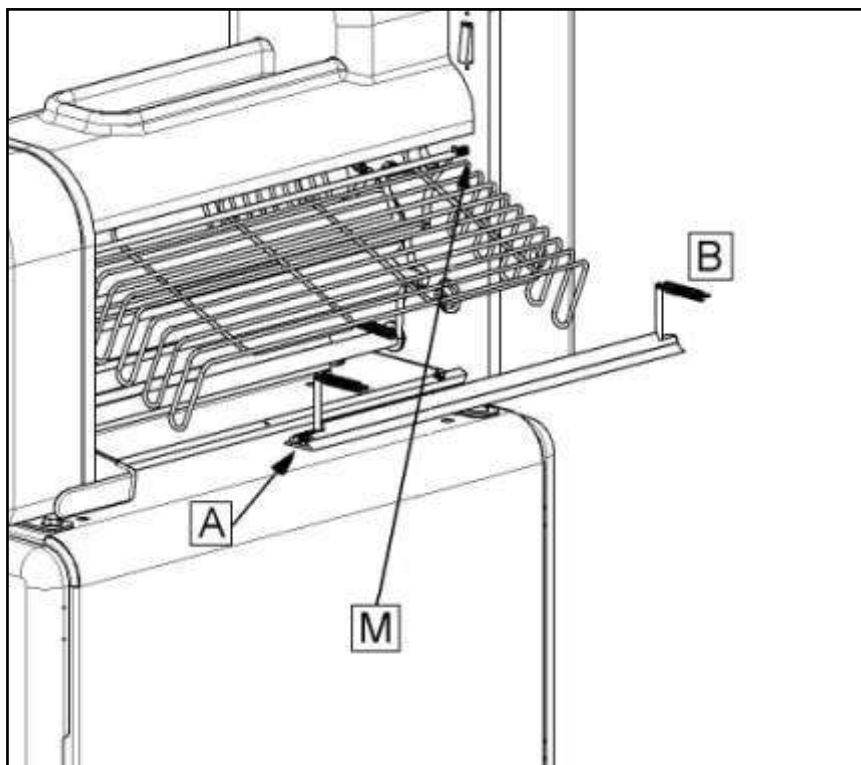

13.1.2. Instruction for the protection grid

For the machine to work, the protection grids must be in low position. Lifting them, they will position themselves in a fixed raised position. To bring them back to work position, press spring M crossways (see arrow) and, while holding it down, lower the grid.

DO NOT FORCE as this would compromise the normal operation of the machine.

13.1.3. Inserting the belts

Grasp the belt with both hands and insert the belt pin (P) in a slightly diagonal position in the appropriate seat (S2) and press it against the spring. Insert the milled belt pin (C) in seat (S1) on the machine. If the grooves do not match, turn the pin (C) until it fits between the two seats. By releasing the pressure on the pin spring (S2), the belt will lock in its seat. The belt can rotate around the axis (C-P), to bring it to work position simply rest the diagonal rod (A) on the base.

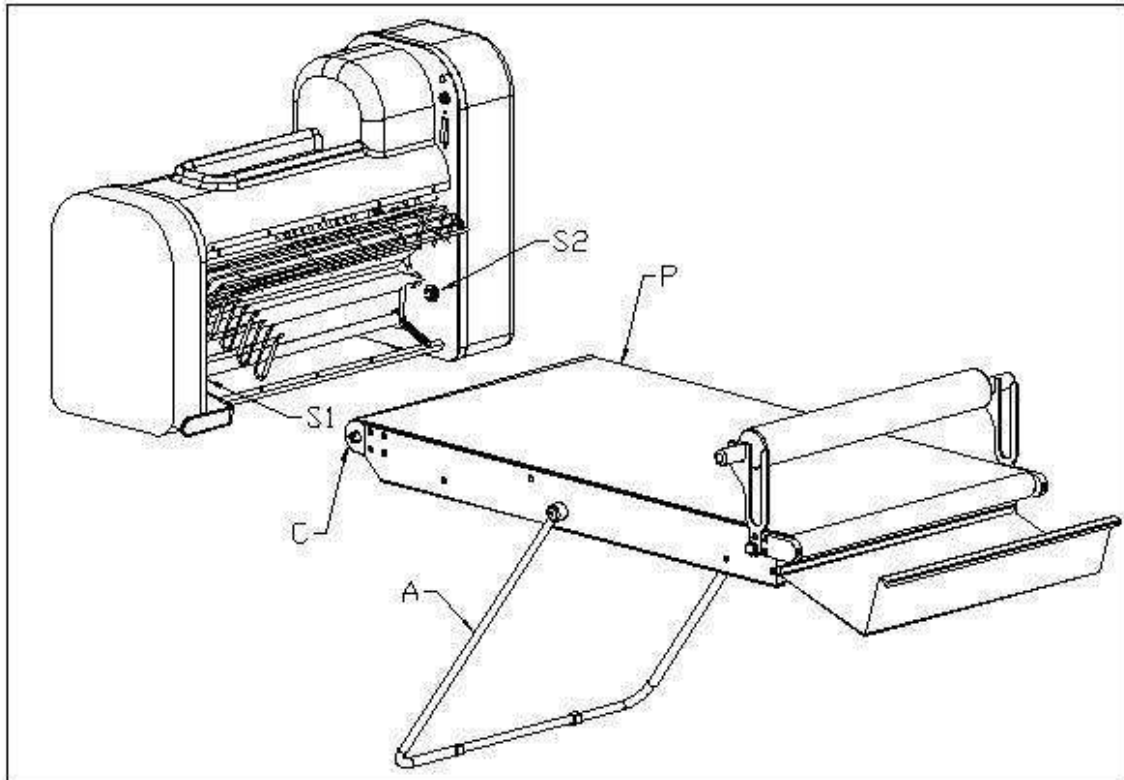

13.2. Machine operation

The commands

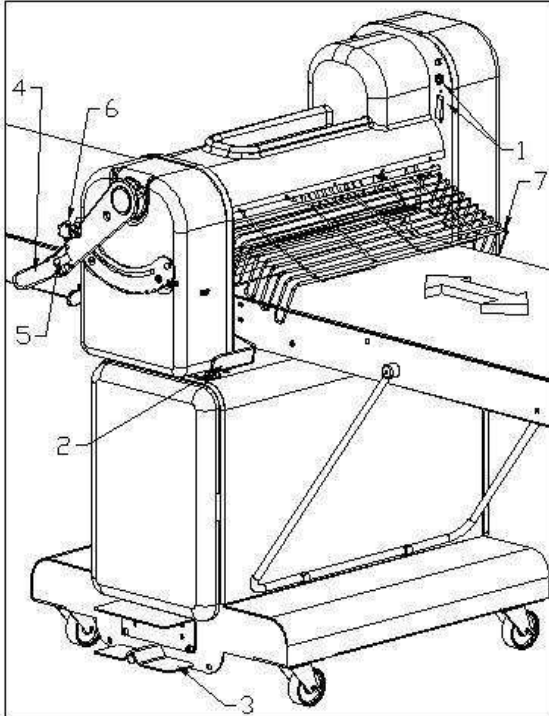

- 1) Master switch with mains LED lamp.
- 2) Control lever and motion reverse.
- 3) Control pedal and motion reverse (on request).
- 4) Rolling thickness adjustment lever.
- 5) Lever release (4)
- 6) Lever stop handwheel (4)

13.2.1. First start-up

Make sure the protection grids are lowered before any manoeuvre with current connected. To start the machine, simply press button 1, the closing of the circuit is indicated by the close-by LED lamp. To test proper connection, lower lever 2 as shown in the figure, the belt will move in the direction of the arrow. Otherwise, reverse a pair of wires of the current socket. If the machine is equipped with pedal, carry out the same test. Finally, test the rollers adjustment lever, to near them simply move lever 4 from right to left, even with small taps of the palm. A specific crack allows for movement in a single direction, to bring it back to open position, press lever 5 to release the crack and allow the lever to move freely. Once the desired dough thickness is defined, you can "store" it by means of handwheel 6 which prevents the adjustment lever from advancing beyond the desired point. Check that the machine is stable and that the belts and rod wipers are properly inserted. Finally, check the operation of the safety micro-switches controlling the protection grids; the machine should stop when they are raised. The machine is now operational.

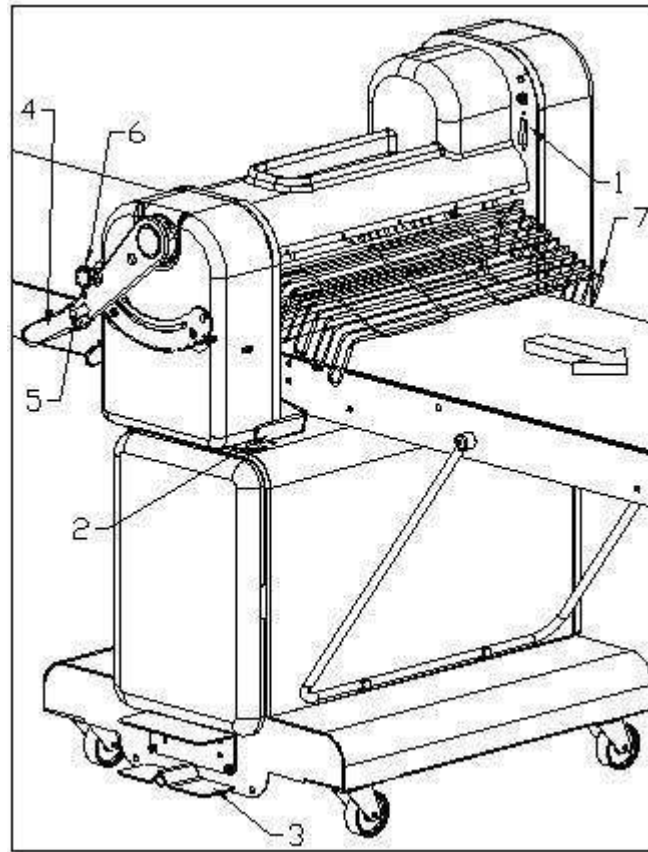

13.3. Operation

13.3.1. Operational functioning

In its more classical execution, the sheeter is used to produce puff pastry. For other uses, contact the sales department, a series of special belts are available for larger doughs or other.

To roll the pastry, place a ball made from alternating layers of dough and butter or margarine, on the belt. When required, it is necessary to sprinkle flour on the contact areas of the ball with the belt and rollers; a groove to contain the flour for this purpose has been obtained in the central area of the head. Adjust the rollers to reduce the thickness by 10-15% and start the machine. The ball is dragged towards the rollers and compressed by them, thus reducing the thickness, with elongation and expansion of the ball. Once all the dough has come out from the rollers, reverse motion by acting on lever (2) or pedal (3); the rollers simultaneously tighten for a new rolling. As the process advances, the pastry becomes longer, and for this reason there are two dough containment trays at the end of each belt. When these are not longer enough, rolling pins are used on which the dough is wrapped.



13.3.2. End of work

To clean the machine, remove scales from the rollers and belt. Disassemble the rod wipers and clean them thoroughly, their good condition makes the machine work better.

SAFETY RECOMMENDATIONS:

The area around the machine must be well lit, free from other objects and clean.

Personnel must wear adequate clothing for running the machine, non-slip shoes protected with tip, sleeves tight around the wrist, prohibition not wear dangling clothing or floating limbs (ties, napkins, torn clothes, open jackets, etc.) to prevent the risk of entanglement.



EARTHING CONNECTION: it is compulsory to check the efficiency of the earthing system of the machine. Faulty or incorrect connection may cause serious injury, even death.

ELECTRICAL PANEL, GENERAL PROVISIONS:

Unauthorised personnel is not permitted to open the electrical panel. Never leave the machine unattended with electrical parts exposed.

Machine operation with electrical parts exposed is only admitted in the presence of qualified personnel, only for short periods to perform repairs and under the responsibility of the person in charge.

14. Replacements and/or scheduled maintenance



FOR ANY MAINTENANCE AND CLEANING OPERATION, IT IS COMPULSORY FOR THE MACHINE TO BE SWITCHES OFF AND DISCONNECTED FROM THE MAINS.

MOVE YOUR HANDS AWAY FROM THE BELT BEFORE STARTING THE MACHINE, DURING TESTS AND DURING MACHINE USE

Replacements and/or scheduled maintenance of parts prone to extreme wear, with information on CLEANING AND MAINTENANCE OPERATIONS, allow the machinery to last longer.

Scheduled replacements of parts prone to extreme wear, with information on CLEANING AND MAINTENANCE OPERATIONS.

	<p>CHECKING THE INSTALLED SAFETY SYSTEMS AND ELECTRICAL SYSTEM</p> <p>The installed safety systems and the electrical system are subject to periodical checks carried out by a specialised electrician.</p>
---	---

Key of check intervals: INTERVALS	Key of how to carry out the checks: METHODS
d = daily. w = weekly. m = monthly. a = annually.	O = Observation: requires simple visual check (i.e. alarm light) F = Function: requires a physical check of the action (i.e. pressing the emergency button, the machine must stop) M = Measurements: requires a check with an appropriate instrument (i.e. checking earthing values).

14.1. Master switch

Purpose: protection of power line.

Function: They are used to connect-disconnect any type of electric circuit, this equipment separates the machinery from the mains, it is placed on one side of the machine.

CHECK:

INTERVAL	METHOD
m	F

14.2. Stop circuit and safety micro switch of the grid

Purpose: stop the machine.

Function: the machine stops by pressing the STOP button, ONLY in an emergency does the grid lift. To restore functioning of the machinery, the operator must start the cycle once again by pressing the START button, after completely closing the grids.

CHECK:

INTERVAL	METHOD
g	F

14.3. System checks

Periodically check the working order of the automation of the machine and its earthing. The operating modes, safety functions, terminal board contacts need to be checked as well as the integrity of the cables, luminous LEDs and earthing system.

CHECK:

INTERVAL	METHOD
a	F, M

14.4. Routine maintenance



The machine does not require particular maintenance operations. Every 4-6 months, grease and oil the moving parts (use food grease, i.e. **BECHEM BELORUB FB19**).

Keep the machine clean to prevent flour from depositing in the moving parts thus generating bothersome creaking and abnormal wear.



1) Should a power cable be damaged, replace it with a **H07RN/F** cable with a 3x1.5 mm² section.

In the event of malfunctioning, remove the guard and check the safety micro-switch.

2) Belts and grid micro anomaly (A): remove the gears protection casing, check operation, close the casing and test the machine.

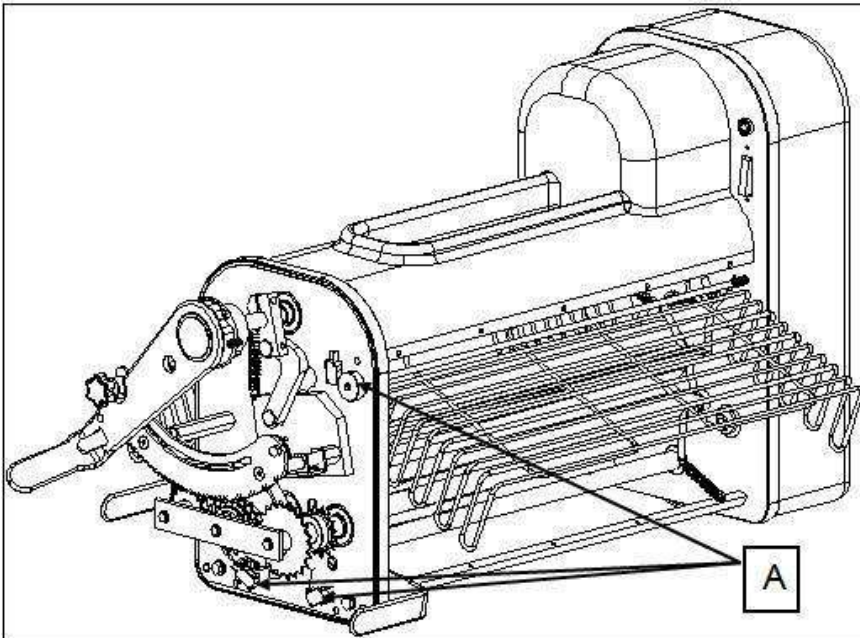

By disassembling the casing from the CLUTCH SIDE, you can access: the speed change unit of the belts and the rollers adjustment.

The machine does not require particular maintenance operations. After the first three months of work, check the wear of the belt.



To tension the belt, loosen the motor bolts and force with a screwdriver (B). Fasten the motor bolts, place the casing back and test the machine.

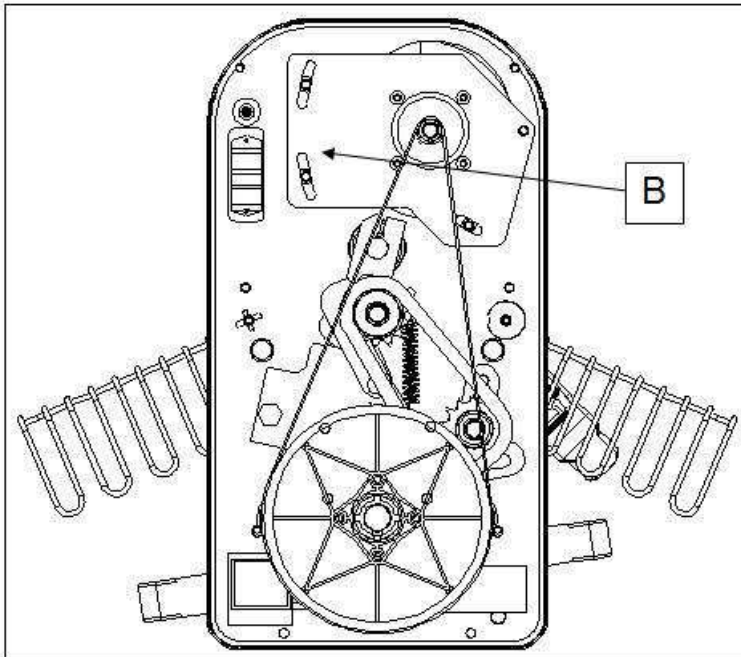

By disassembling the casing from the MOTOR SIDE, you can access: the electric motor, the primary drive belt and the return chain to the clutch unit from the other side.

Electrical system anomalies: remove the gears protection casing, with reference to the diagram, check operation, close the casing and test the machine.

14.5. Replacing the belt and the belts' bearings

To replace the belts and the shaft bearings:

1. Disconnect the belt assembly from the machine by pressing (as indicated by the arrow on the drawing) and remove it.



The protection grids must be raised during this operation.

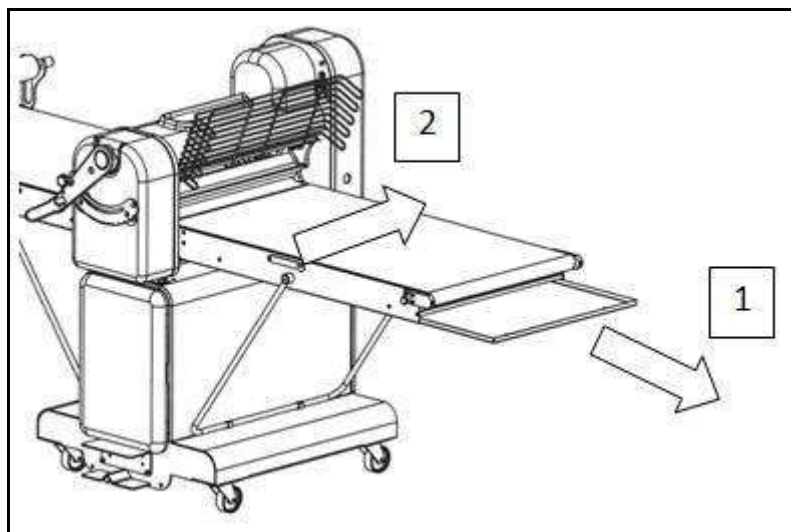

The belt assembly must be placed on a support able to bear its weight, which is of about 30 [kg].

2. Disconnect the support keeping the belt unit raised, loosen the screws (1) on both sides and remove it.

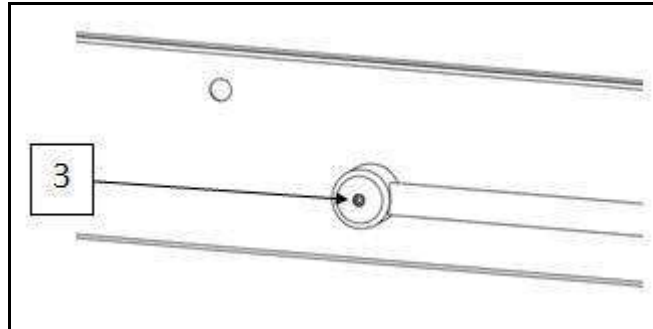

3. To loosen the belt, unscrew the screw (2) of the belt tensioning support on both sides

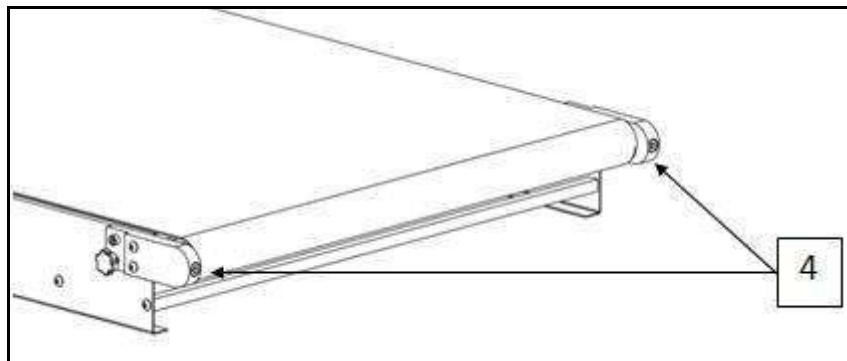

4. To remove the motor roller shaft, loosen the four screws on both sides (3) and remove it from the belt (4).

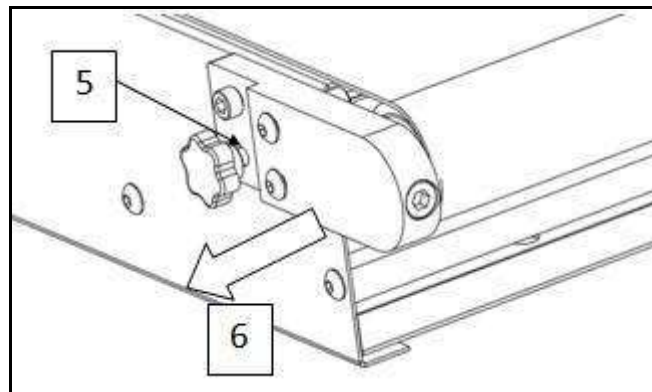

5. To change the bearings, remove the right and left hubs (5) of the shaft, and replace the bearings (6) by slightly pressing with a screwdriver. Insert the new bearing and put the hub back on the shaft.

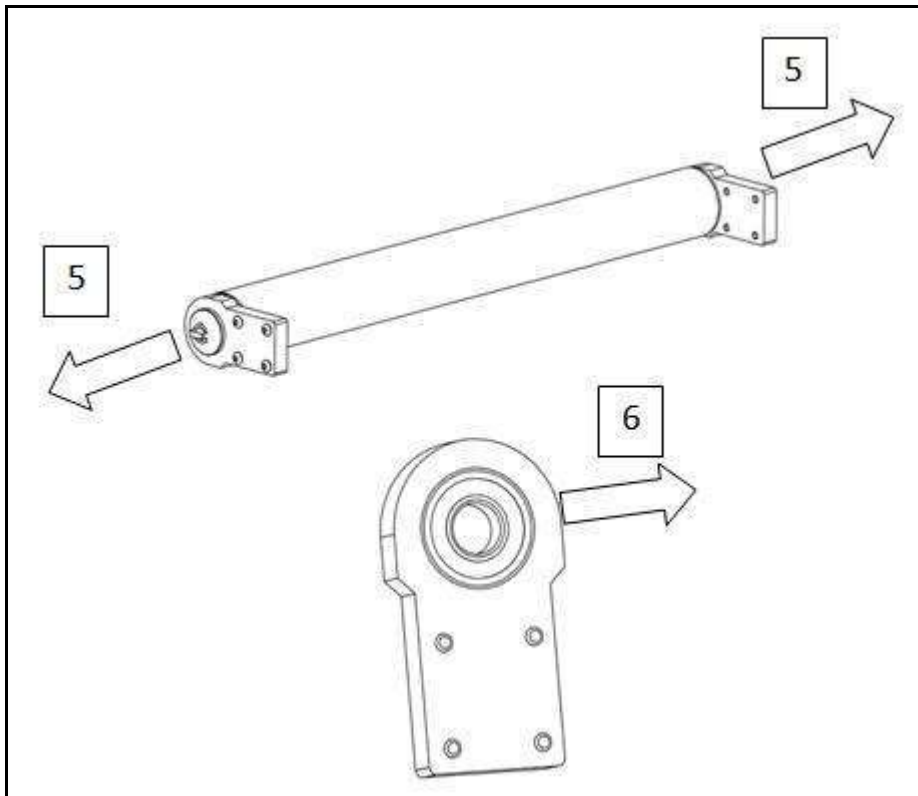

6. To replace the belt, loosen the belt tensioning support on both sides (7), this releases the roller and it can be removed (8).

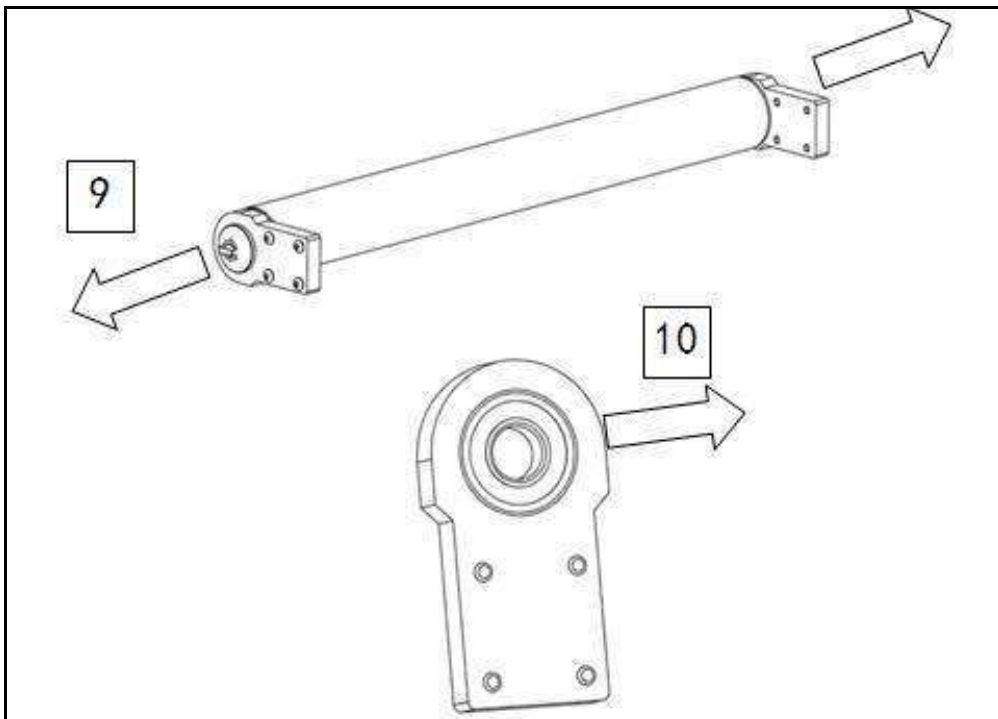

7. Remove the drawer

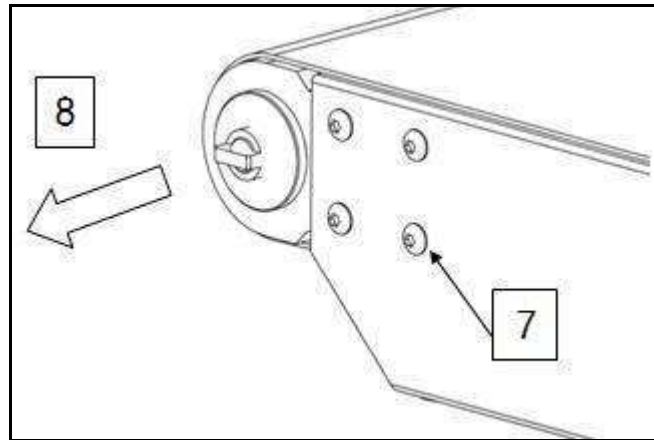

8. Turn the belt assembly. Loosen the screws fixing the support sheet metal tie rods (9), then remove the two or three tie rods from the support sheet metal (10).

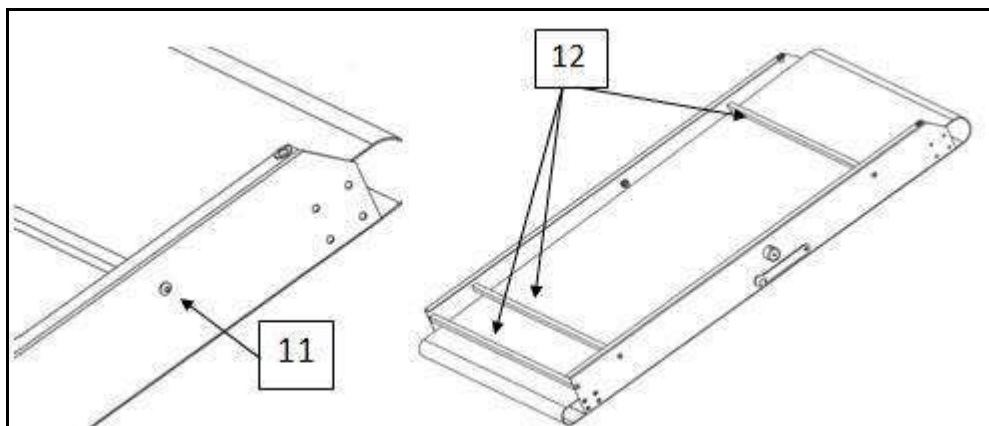

9. It is now possible to remove the belt and insert the new one.

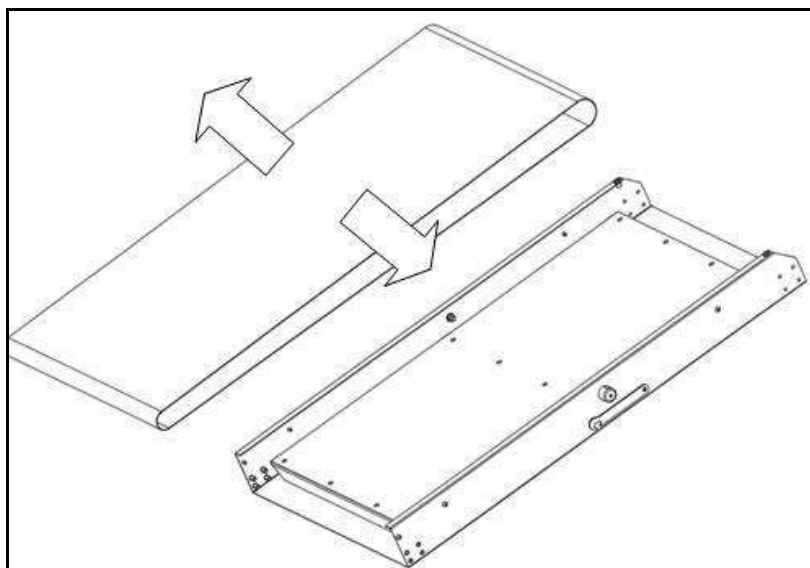

10. To reassemble, repeat the above steps in reverse order. When you have reached the belt draw phase, tighten the belt tensioning support screw for a proper tension, which must be equal to a distance between belt and support of about 7 [mm] (11).

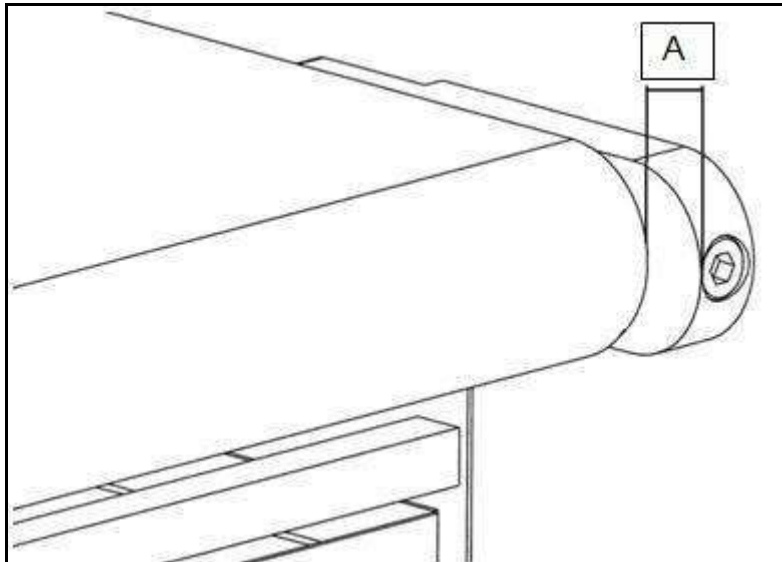

14.6. Protection grid change

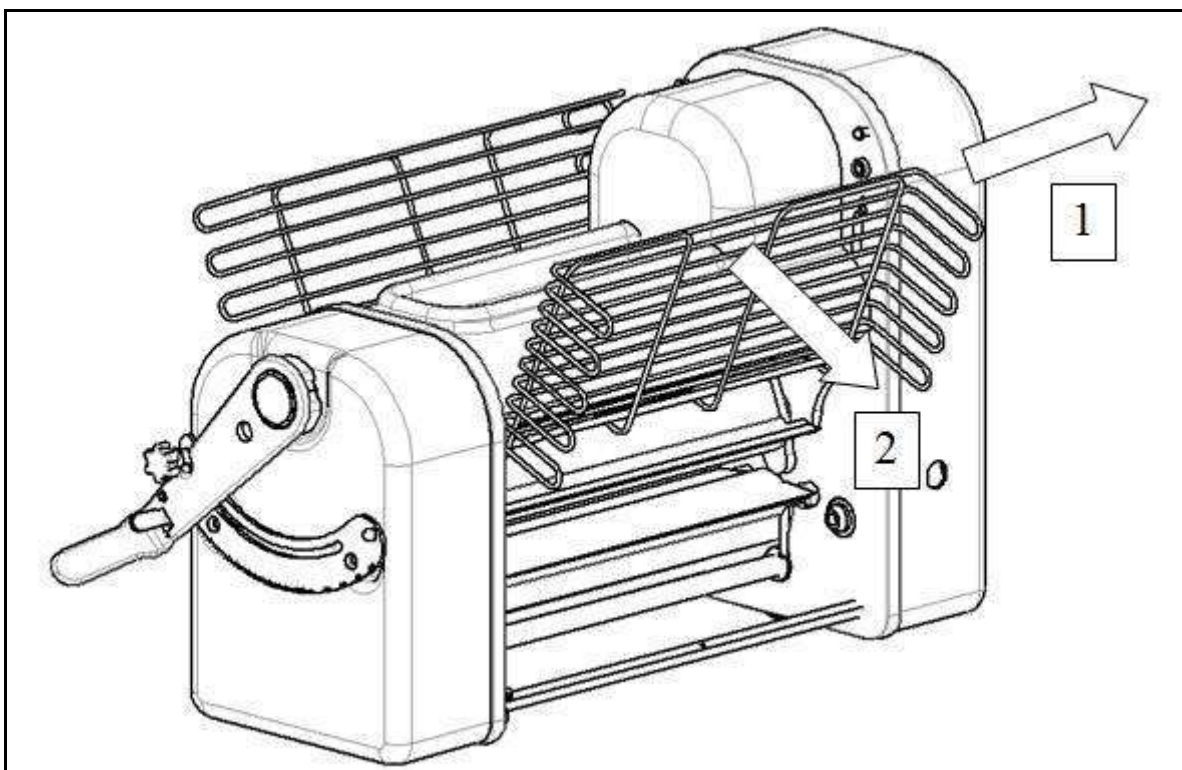

Move the safety grid (1) sideways before lowering it (2) to ensure proper operation of the safety systems.

14.7. Disassembly and cleaning of rod wipers



THE ROD WIPERS MUST BE MANDATORILY DISASSEMBLED AND CLEANED WITH THE MACHINE OFF AND DISCONNECTED FROM THE MAINS.

ATTENTION: the edge of the rod wiper is sharp, handle it with care.

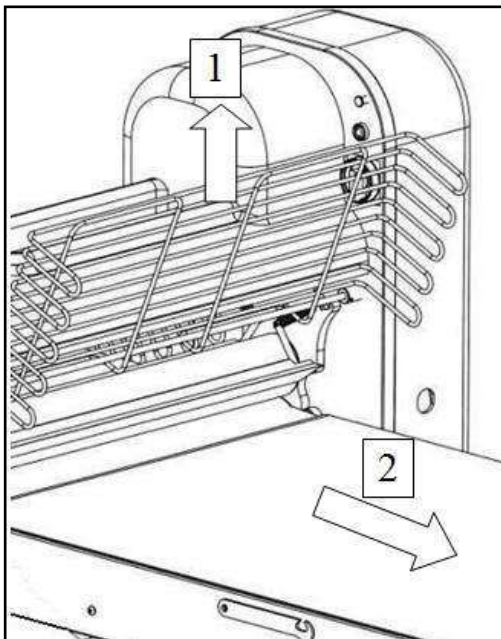

Lift the protection grid;
To help you, remove the belts.

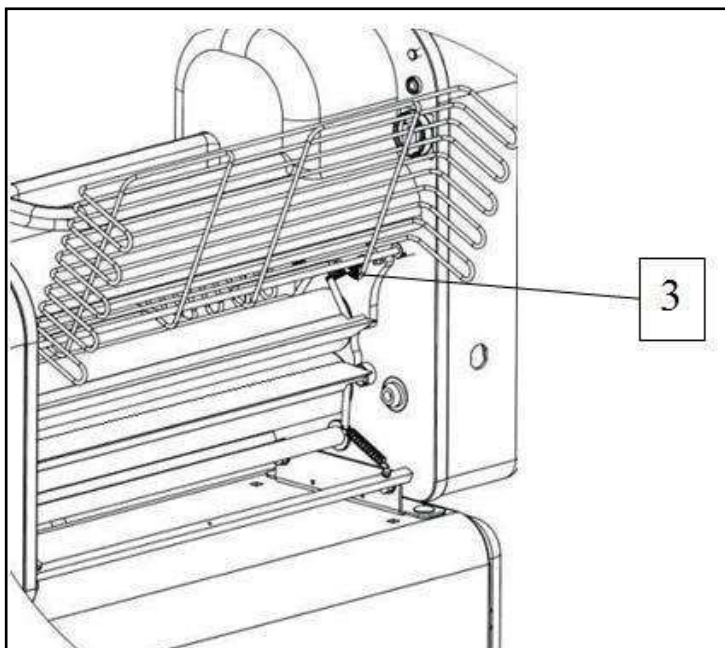

UPPER ROD WIPER

Release the springs on both sides;
To remove the rod wiper, push it from the clutch spring side (7) and then remove it.

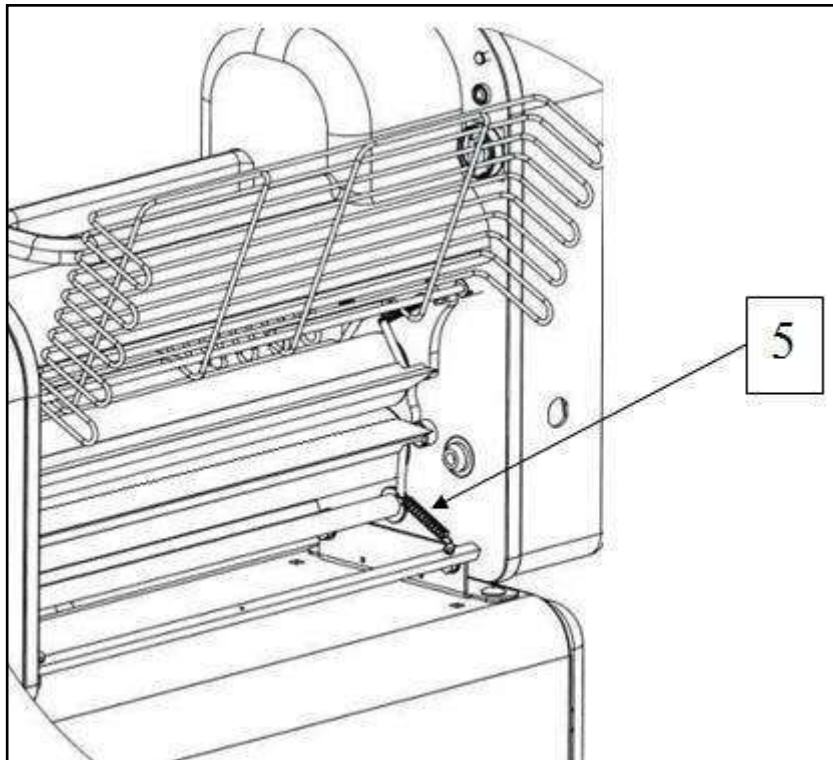

LOWER ROD WIPER

Release the springs on both sides;

To remove the rod wiper, push it from the clutch spring side (7) and then remove it.

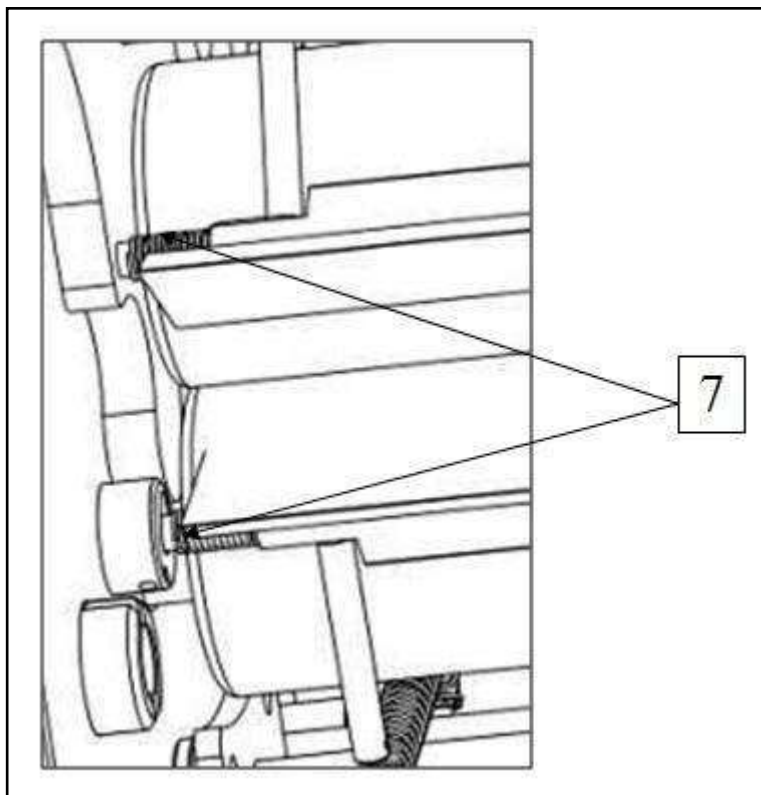

ASSEMBLING THE ROD WIPER

ATTENTION: care must be taken when assembling both rod wipers to the clutch spring, that it is positioned correctly.

Repeat the above described operations in reverse order.



14.8. Extraordinary maintenance

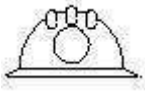

To carry out interventions not specially mentioned in the manual, refer to personnel authorised by the company. To replace the motor or the circuit boards, or else if the machine falls, contact our assistance service for an on-site intervention or an overhaul at the factory.

14.9. Daily maintenance



DAILY CLEANING OPERATIONS AND CHECKS:

Cleaning outside surfaces with cloth and neutral degreasing agent. Cleaning: the machine is not jet-proof. Do not wash it with running water. Clean it with a damp cloth and neutral cleaning products; such as degreasing agents based on Marseilles soap.



15. Troubleshooting

15.1. Blockage of machinery and necessary remedies

Operating faults	Possible causes	Repairs	Performed by
Turning the master switch into position, the warning light does not turn on.	1) Plug not inserted correctly or wires detached. 2) LED lamp on the start/stop button burnt	1) Check connection. 2) Replace lamp.	Personnel authorised by the employer and/or qualified personnel in possession of the technical knowledge of the work.
Pressing the START button, the machine does not start.	1) The protection grid is open. 2) The belts are incorrectly positioned. 3) Safety micro switches anomalies.	1) Rotate it and reposition it in closed position. 2) Check if the correct positioning has been respected. 3) Replace or check the micro switches.	Personnel authorised by the employer and/or qualified personnel in possession of the technical knowledge of the work.
Continuous noise	1) Check the efficiency of chains and bearings.	1) Replace the bearings or grease the chains.	Personnel authorised by the employer and/or qualified personnel in possession of the technical knowledge of the work.
Slight intermittent noise.	1) Lack of lubrication in drive (chains).	1) Grease the chains.	Personnel authorised by the employer and/or qualified personnel in possession of the technical knowledge of the work.
Belt rotation irregular	1) Loose. 2) Worn	1) Belt centring (see chap. 14.4). 2) Belt replacement (see chap. 14.4).	Personnel authorised by the employer and/or qualified personnel in possession of the technical knowledge of the work.

16. Exploded view of machine

Exploded view 1

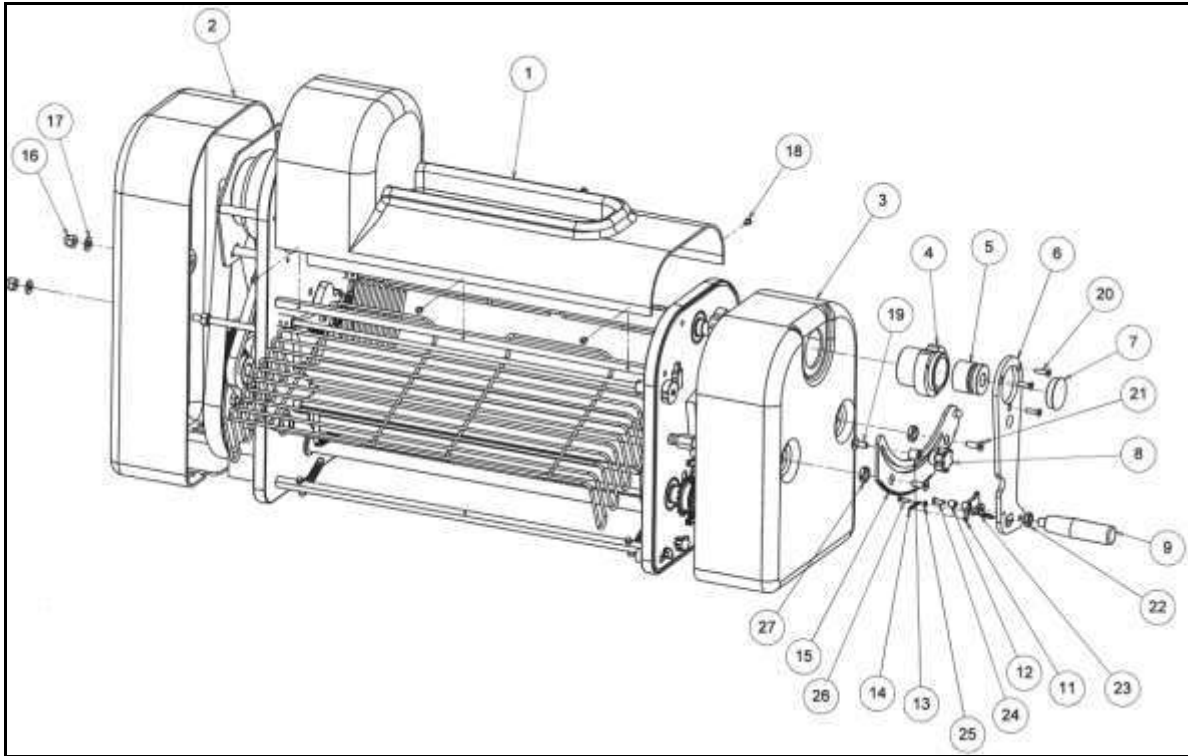

Exploded view table 1

Pos.	Drawing	Description	Q.ty
1	03174075	MOTOR CASING	1
2	03174004-3	MOTOR THRUST CASING	1
3	03174003	CLUTCH THRUST CASING	1
4	85174039-1	HANDLE HUB	1
5	14000508	SHRINK DISC	1
6	85174037-5	HANDLE SUPPORT	1
7	14002609	PIPE HEAD COVER	1
8	14002008	HANDWHEEL	1
9	14002502	HANDLE KNOB	1
10	85174091-1F	COMMANDS LEVER ASSEMBLY FOR SFG 500 B	1
10	14002503	LEVER COVER KNOB	2
11	84174142	HOOK LEVER	1
12	15000516	6-10-10 BUSHING	1
13	01174041	HANDLE STOP SPACER	1
14	08174040	HANDLE SPRING	1
15	85174036-1	GRADUATED SECTOR	1

Exploded view 2

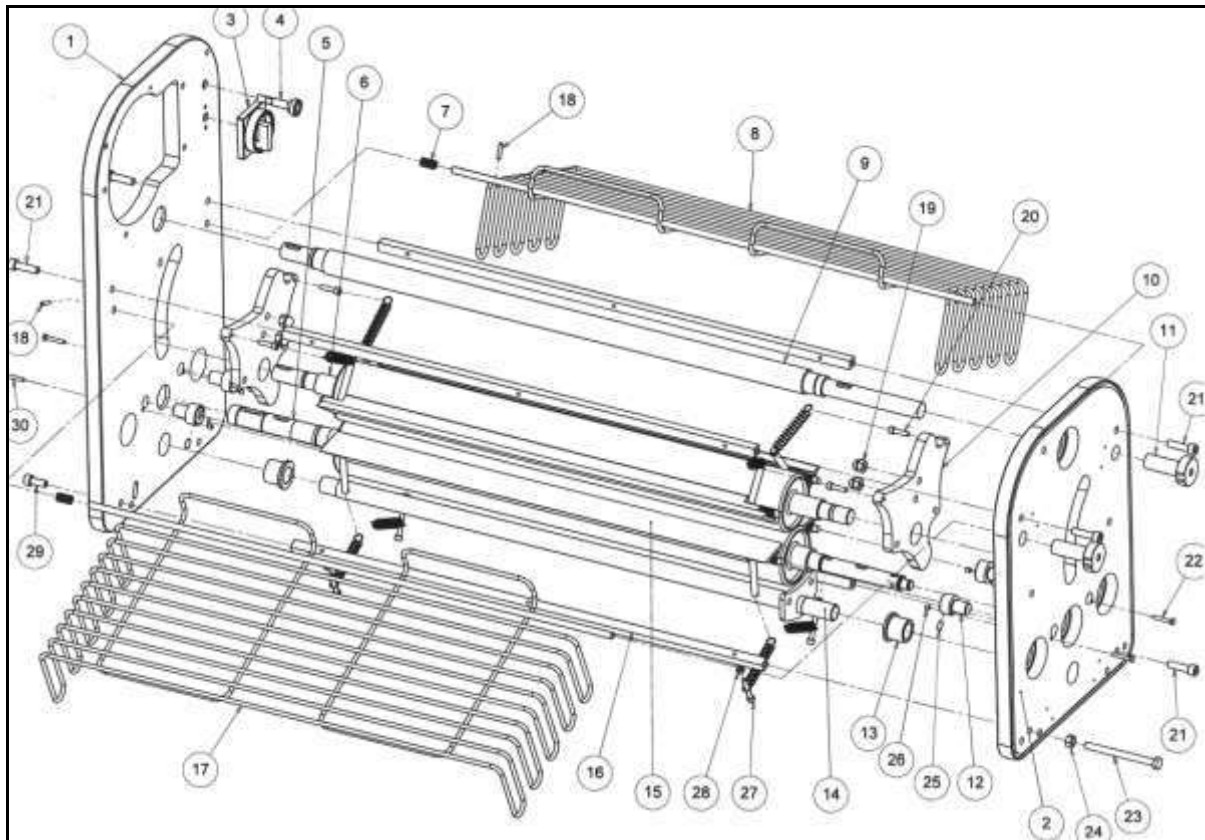

Exploded view table 2

Pos.	Drawing	Description	Q.ty
1	01174002-8	MOTOR SIDE THRUST	1
2	01174001-4	CLUTCH SIDE THRUST	1
3	25003009	MASTER SWITCH	1
4	25009027	MAINS LED	1
5	85174094-2	FIXED CYLINDER ASSEMBLY	1
6	85174093-1	MOBILE CYLINDER ASSEMBLY	1
7	08072075	ROD WIPER SPRING	1
8	87174085-1	RIGHT GRID ASSEMBLY	1
9	85174088	HANDLE UPPER TIE ROD	1
10	01174046	ROD WIPER SECTOR	1
11	85174061-1	GRADUATED MICRO CAM	1
12	85174047	LOWER ROD WIPER CENTRING PIN	1
13	15000507	18-28-25 BUSHING	1
14	174059-2	BELTS CONTROL ASSEMBLY	1
15	01174087	MOBILE ROD WIPER	1
16	85174089-2	UPPER TIE ROD	1
17	87174085-1	LEFT GRID ASSEMBLY	1

Exploded view 3

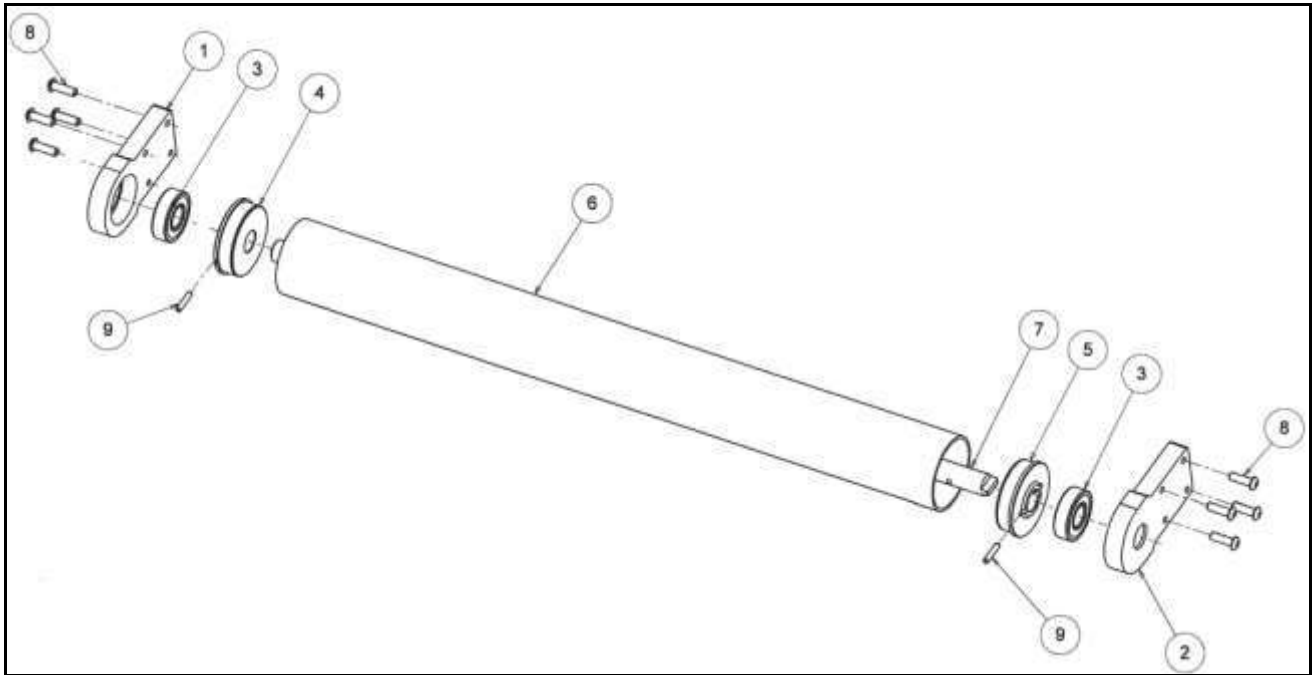

Exploded view table 3

Pos.	Drawing	Description	Q.ty
1	85087056	LH MOTOR ROLLER HUB	1
2	85087057	RH MOTOR ROLLER HUB	1
3	13000014	BEARING 6203 17-40-12	2
4	85087057	RIGHT ROLLER CAP	1
5	85087056	LEFT ROLLER CAP	1
6	01174082	MOTOR ROLLER PIPE	1
7	01174083	MOTOR ROLLER SHAFT	1
9	DIN 1481	SPRING PLUNGER Φ 4x36	2

Exploded view 4

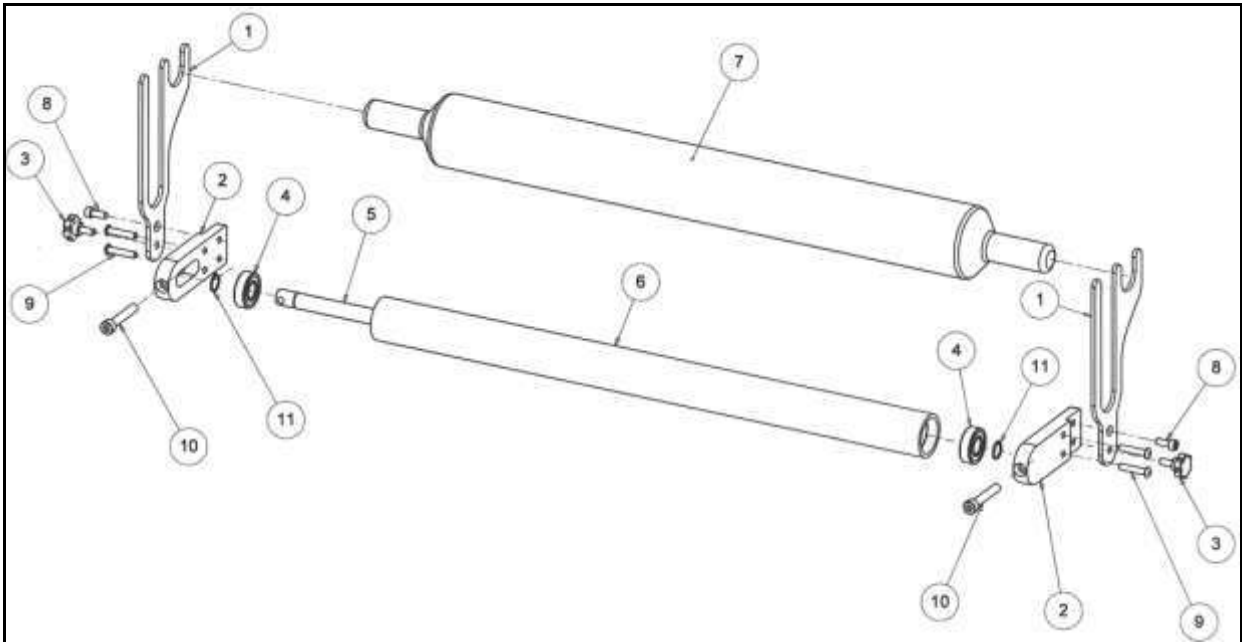

Exploded view table 4

Pos.	Drawing	Description	Q.ty
1	85174022-1	ROLLING PINS SUPPORT	4
2	01174025-1L	BELT TENSIONING SUPPORT	2
3	14002008	HANDWHEEL	2
4	13000313	BEARING 6202 15-35-11	2
5	01174081	IDLE ROLLER SHAFT	1
6	85174080	IDLE ROLLER PIPE	1
7	01072092	ROLLING PIN	2
8	DIN 912	SCREW M6x15	2
9	UNI EN ISO 7380	SCREW M6x30	4
10	DIN 912	SCREW M8x50	2
11	DIN 471	SEEGER Ø15	2

Exploded view 5

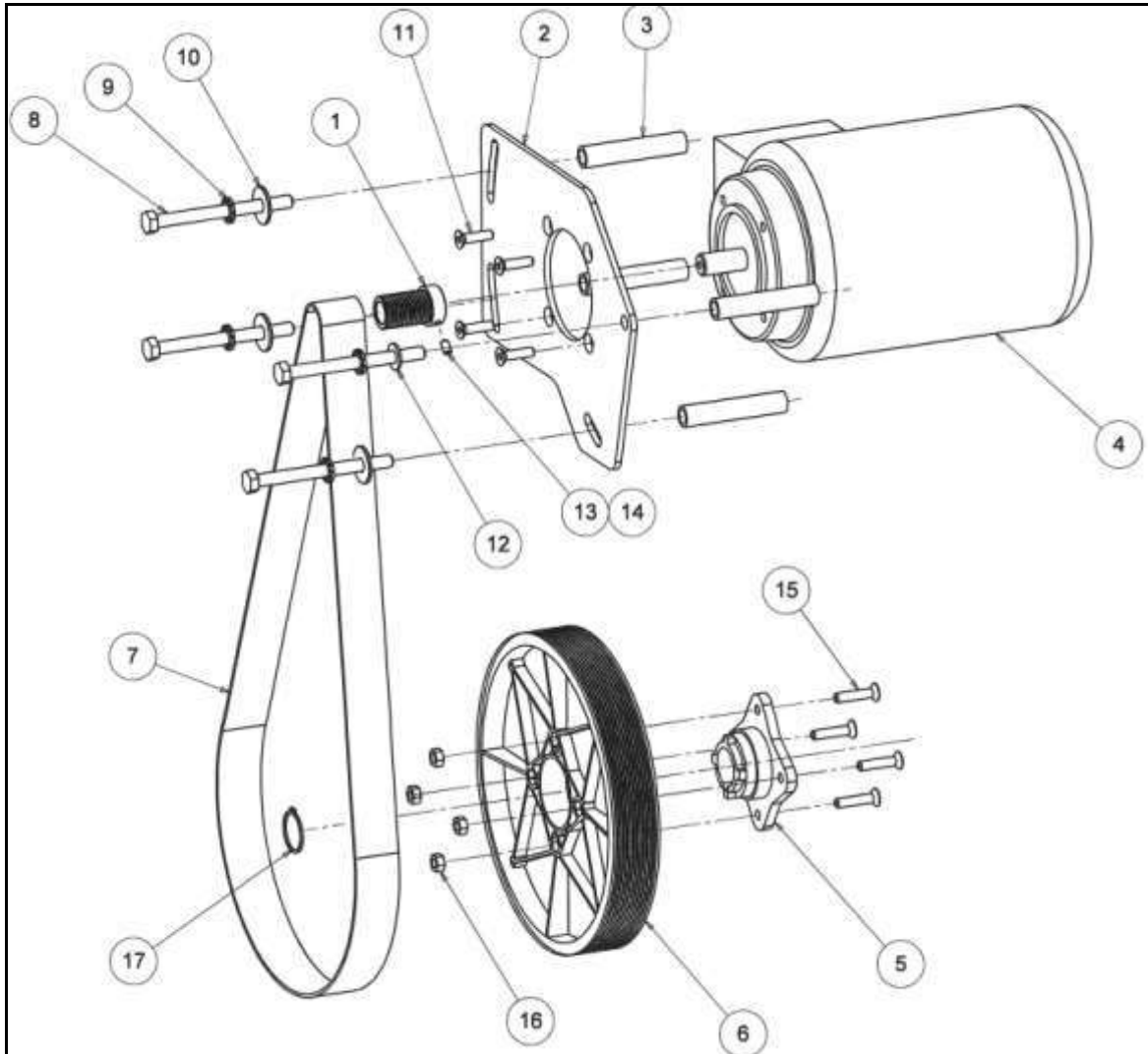

Exploded view table 5

Pos.	Drawing	Description	Q.ty
1	01174070	MOTOR PULLEY	1
2	85174035-1	MOTOR PLATE	1
3	01174071	MOTOR PLATE SPACER	4
4	11000501	MOTOR T71 4P 0.55 kW 400V 50Hz THREE-PHASE	1
5	01087035	REDUCTION CROWN HUB	1
6	01174072	PULLEY Z80	1
7	12003949	POLY-V BELT 430J	1

Exploded view 6A

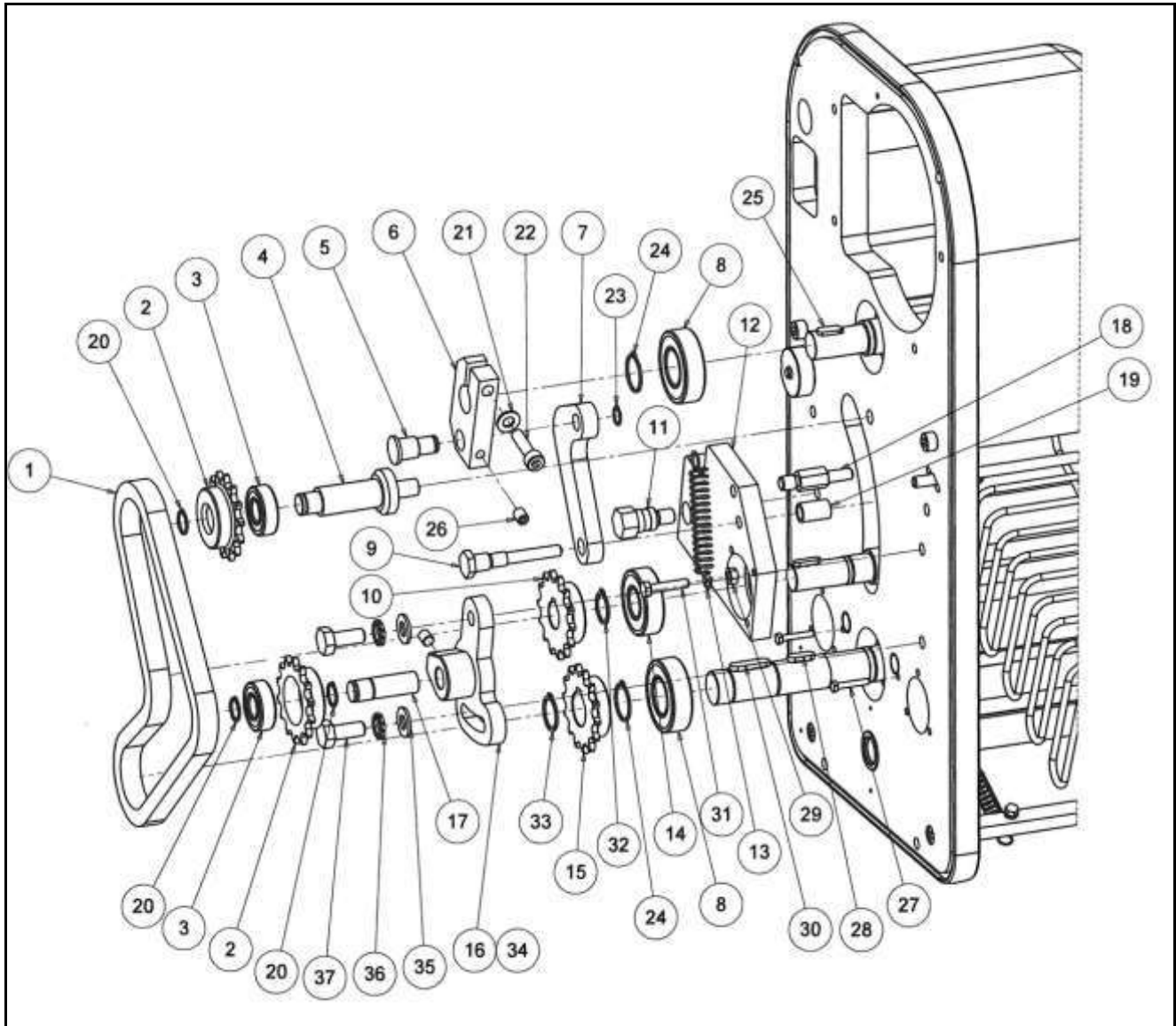

Exploded view table 6A

Pos.	Drawing	Description	Q.ty
1	12000101	CYLINDER CHAIN	1
2	01091009	PINION Z14	2
3	13000313	BEARING 6202 15-35-11	2
4	01174069-2	IDLE PINION PIN	1
5	01091014	ECCENTRIC OPPOSITE PIN	1
6	01174054	UPPER LEVER	1
7	01174053	CYLINDER MOVEMENT LEVER	1
8	13000316	BEARING 6205 25-52-15	1
9	01174048	CYLINDER PLATE PIN SCREW	1

Pos.	Drawing	Description	Q.ty
10	01091009	PINION Z14	1
11	01174051	CYLINDER PLATE PIN	1
12	01174050	MOBILE CYLINDER PLATE	1
13	08072079	PEDAL MICRO SPRING	1
14	13000315	BEARING 6204 20-47-14	1
15	01091009	PINION Z14	1
16	01072017	TENSIONER SUPPORT	1
17	01072018	TENSIONER PIN	1
18	80174068-3	ROD WIPER SECTOR FIXING PIN	1
19	01174100	ROD WIPER SPACER	1

Exploded view 6B

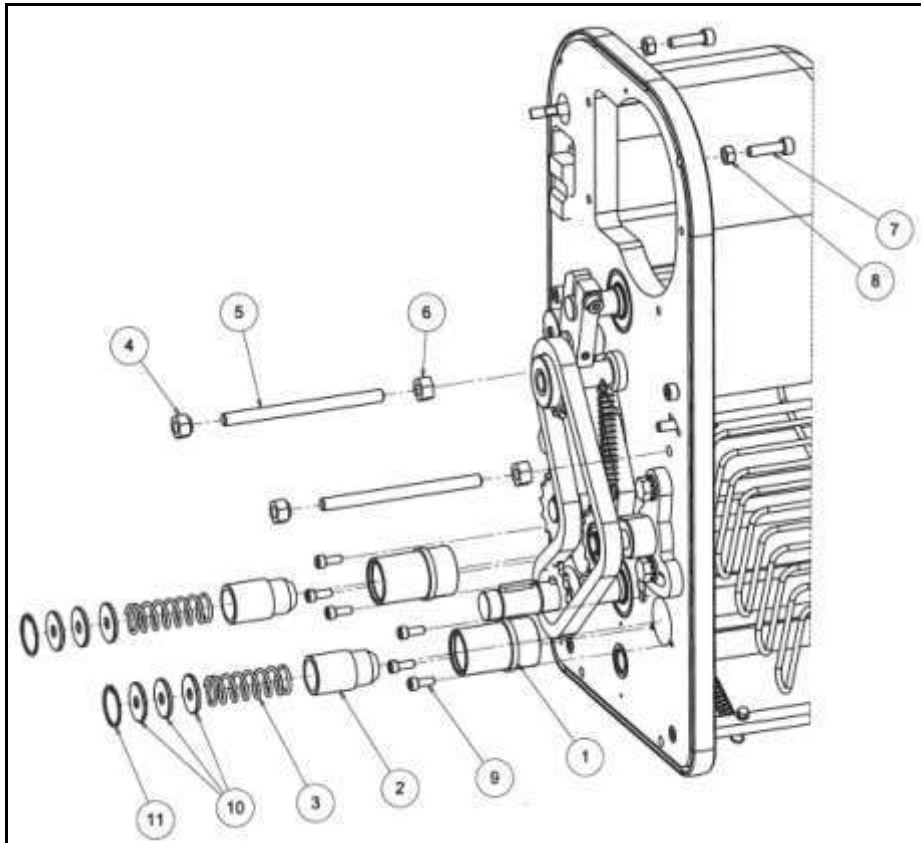

Exploded view table 6B

Pos.	Drawing	Description	Q.ty
1	85174067	BELT SPRING SUPPORT	2
2	01072054	BELT CYLINDER SUPPORT	2
3	08072055	BELT HOOK SPRING	2

Exploded view 7A

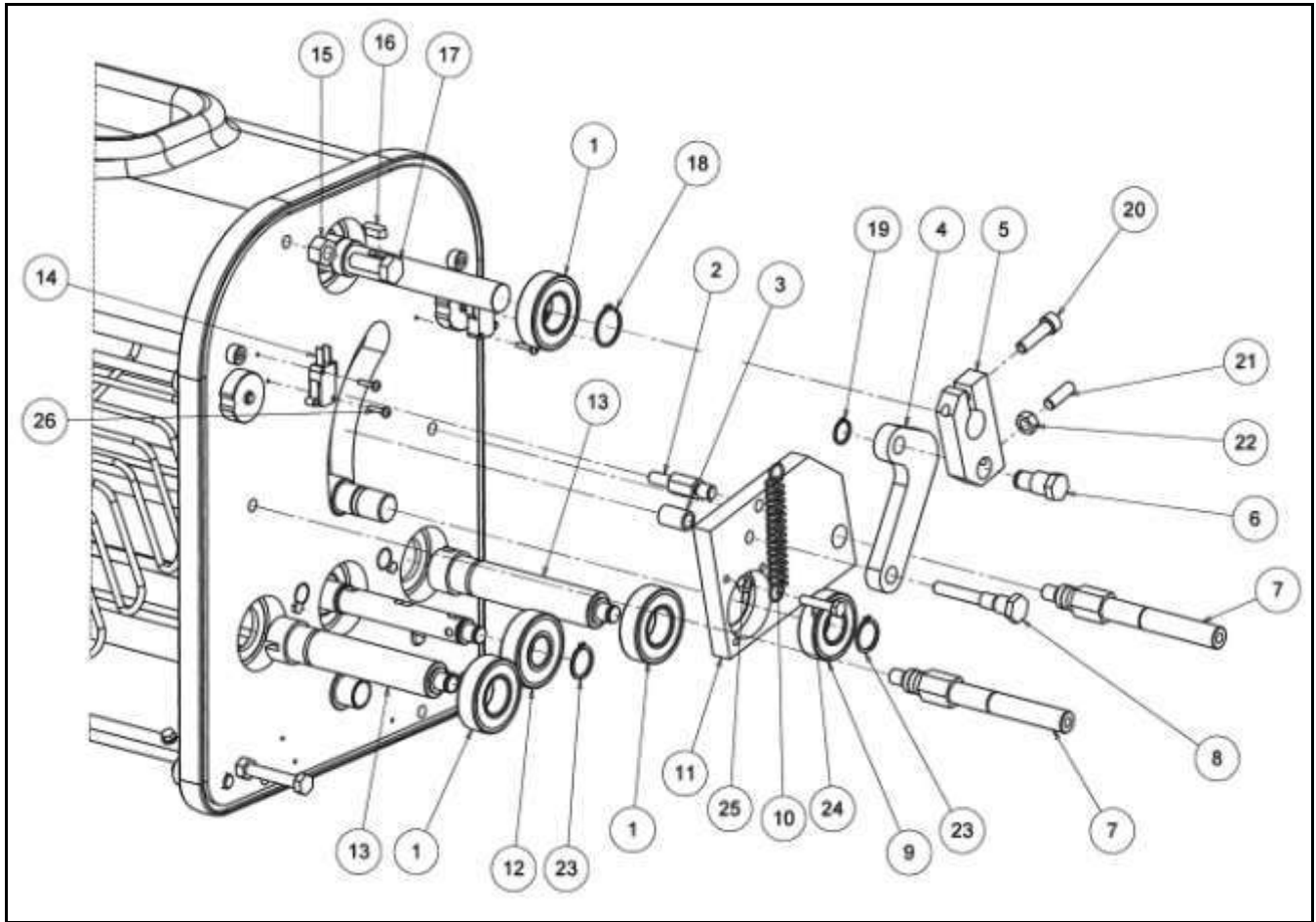

Exploded view table 7A

Pos.	Drawing	Description	Q.ty
1	13000316	BEARING 6205 25-52-15	3
2	80174068-3	ROD WIPER FIXING PIN	1
3	01174100	SCRAPER SECTOR SPACER	1
4	01174053	CYLINDER MOVEMENT LEVER	1
5	01174054	UPPER LEVER	1
6	01091015	ECCENTRIC	1
7	01174051	CYLINDERS PLATE PIN	2
8	01174048	CYLINDERS PLATE PIN SCREW	1
9	13000315	BEARING 6204 20-47-14	1
10	08072079	PEDAL MICRO SPRING	1
11	01174050	MOBILE CYLINDER PLATE	1
12	13000325	BEARING 6304 20-52-15	1
13	85174065-2	MOTOR ROLLER DRAG SHAFT	2
14	25001311	CROUZET MICRO	1

Exploded view 7B

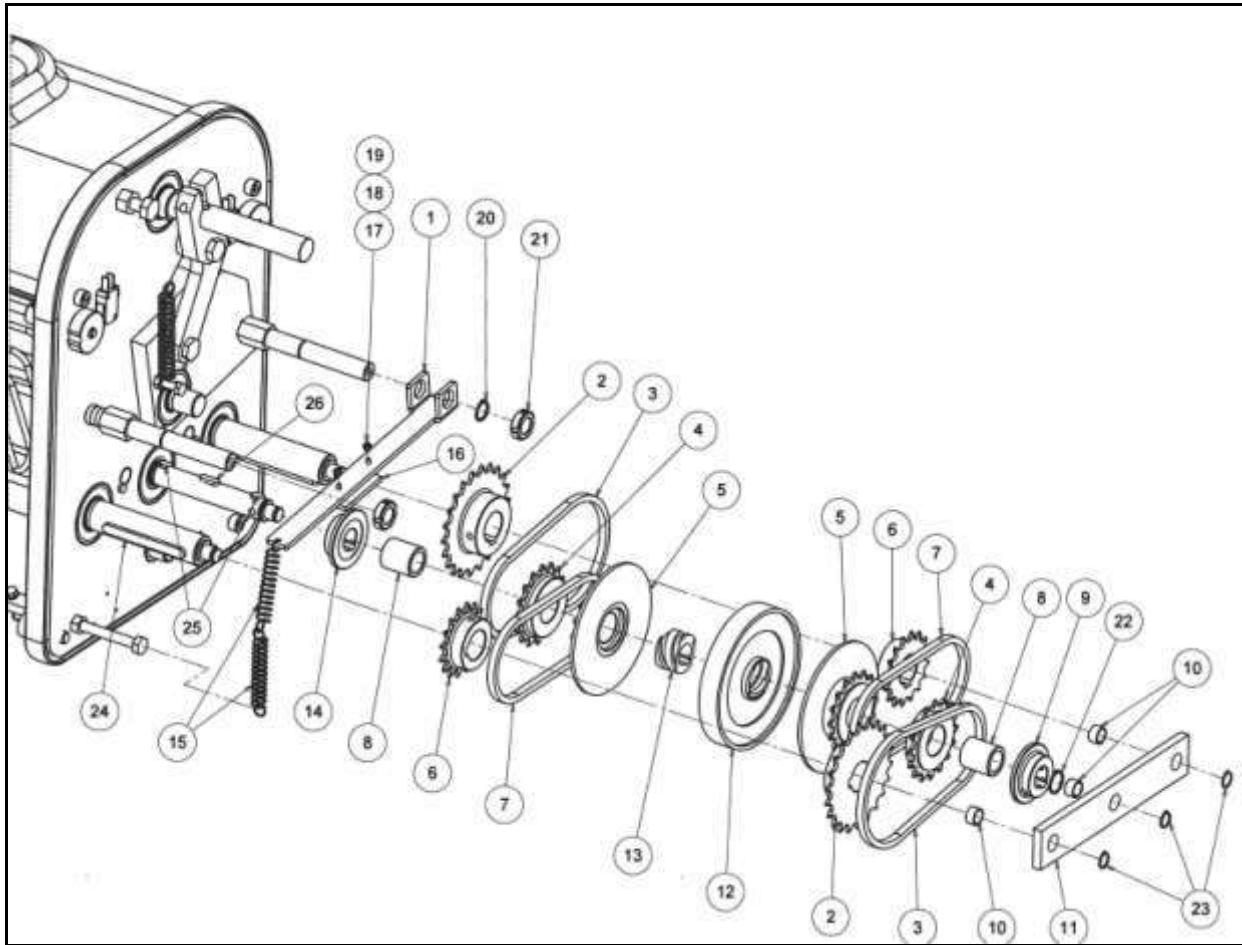

Exploded view table 7B

Pos.	Drawing	Description	Q.ty
1	02174066	BRAKE HOLDER PLATE	1
2	01072049	BELT PINION Z22	2
3	12000002	33-STEP CHAIN	2
4	01072044-1	CLUTCH PINION Z16	2
5	80072043-3	CLUTCH FLANGE DISC	2
6	01072048	CLUTCH PINION Z14	2
7	12000001	29-STEP CHAIN	2
8	15000516	18-25-28 BUSHING	2
9	01072045	CLUTCH FLANGE	1
10	15005002	KU 12-14-L8 BUSHING	3
11	01072047	CLUTCH SHAFTS ALIGNMENT PLATE	1
12	01072040	CLUTCH HOLDER DISC	1
13	01072039	CLUTCH LEAD NUT	1
14	01072045	CLUTCH FLANGE	1

Pos.	Drawing	Description	Q.ty
15	08091045	ROD WIPER TENSIONING SPRING	2
16	14000941	BRAKE LINING	1

Exploded view 8 (FOR OVER THE COUNTER SFG 500)

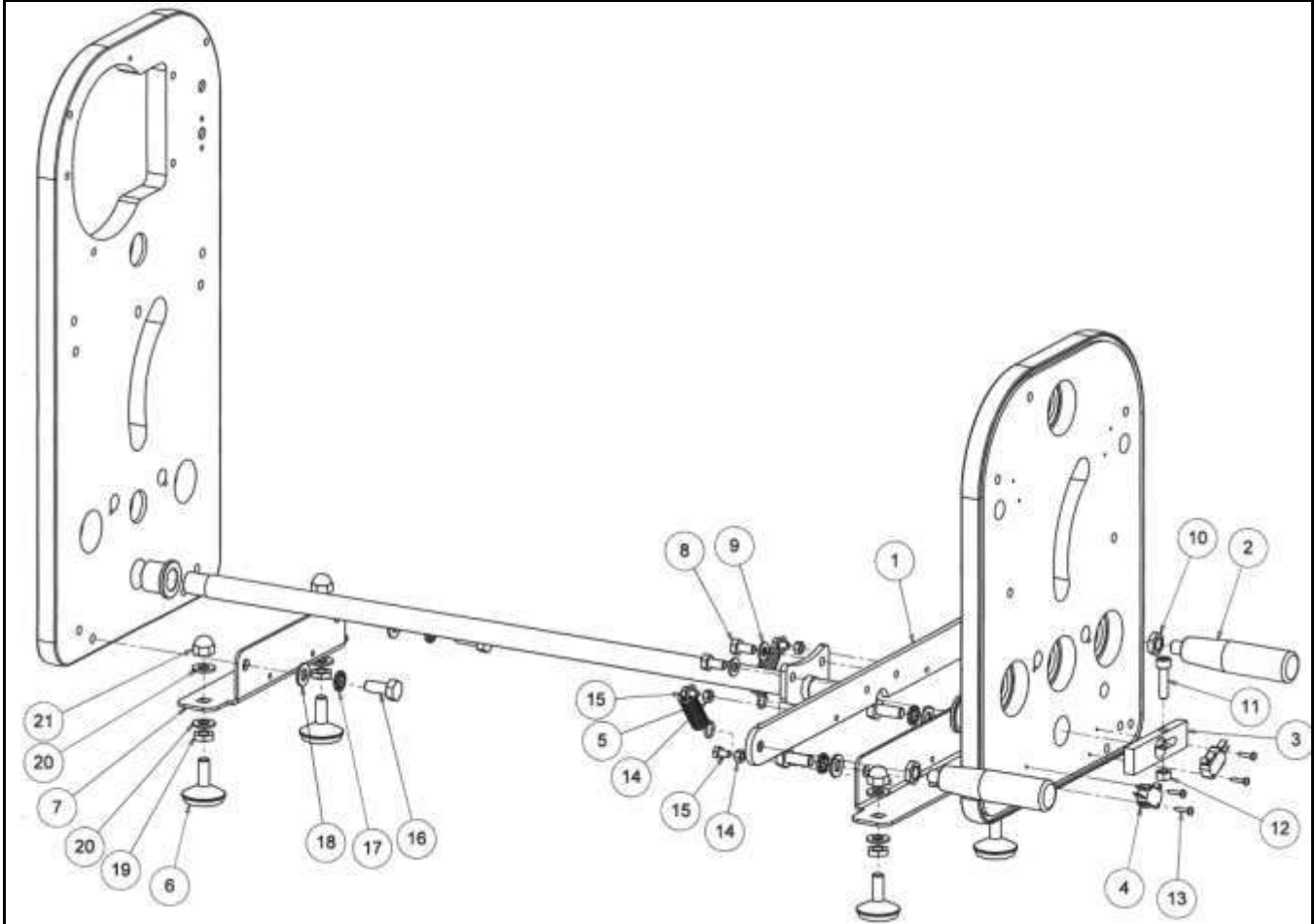

Exploded view table 8 (FOR OVER THE COUNTER SFG 500)

Pos.	Drawing	Description	Q.ty
1	85174058-1	DRIVING BELT	1
2	14002502	HANDLE	2
3	01174060	BELTS MICRO PLATE	1
4	00003296	MICRO SWITCH	2
5	08174182	HANDLE SPRING	1
6	14002801	BLACK FEET M10 D40	4
7	86174010	THRUST FIXING ANGLE BAR	2

Exploded view 9

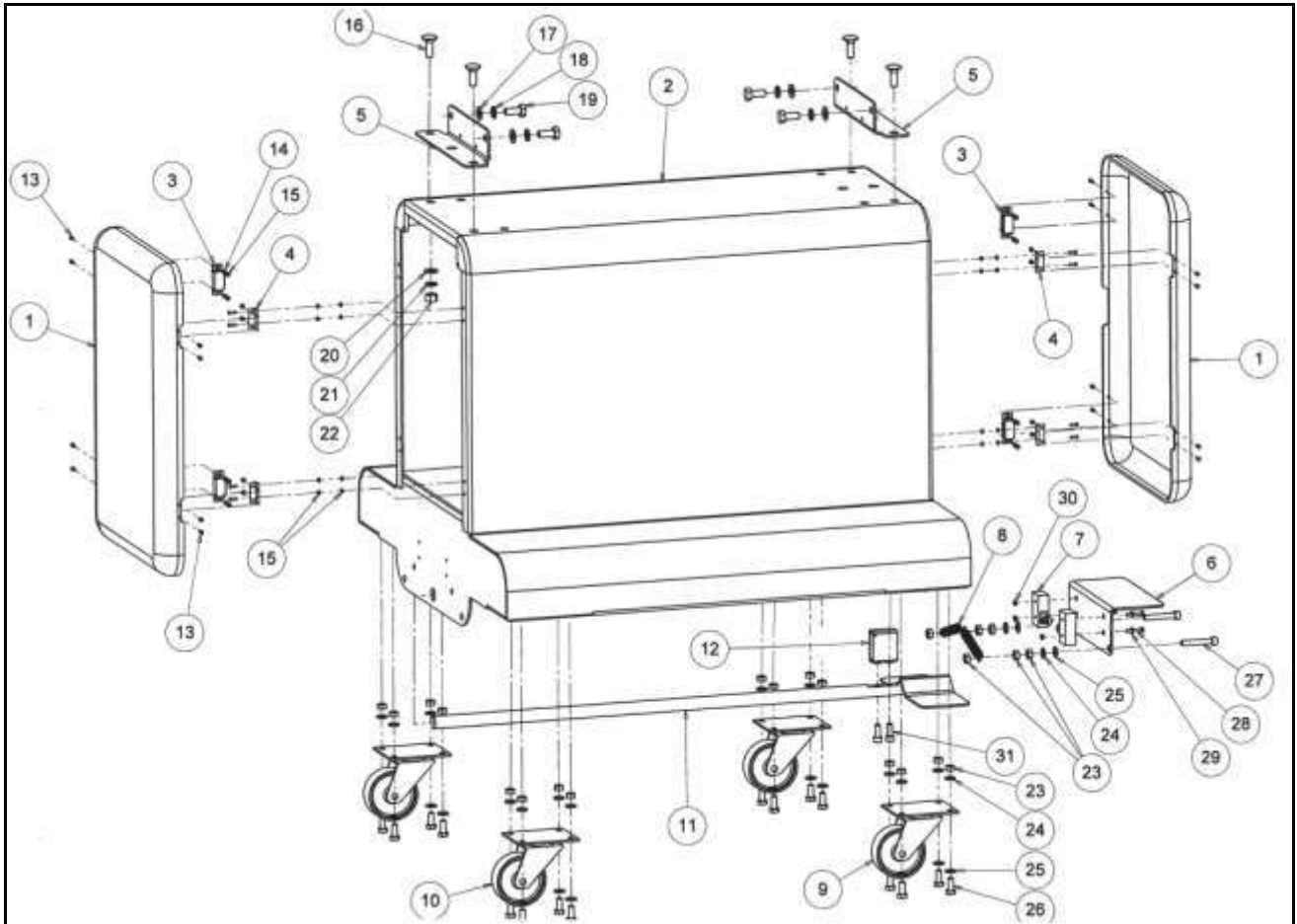

Exploded view table 9

Pos.	Drawing	Description	Q.ty
1	03174018-2	BASE COVER	2
2	86174012	BASE BODY	1
3	23000702	PERMANENT MAGNET	4
4	23000721	SEMI-HINGE	4
5	86174010	THRUST FIXING ANGLE BAR	2
6	86174013	PEDAL COVERING SHEET METAL	1
7	25001308	WHEEL MICRO	1
8	08072079	MICRO PEDAL SPRING	1
9	17000044	WHEEL	2
10	17000042	WHEEL	2
11	85174016	PEDAL ASSEMBLY	1
12	01174017	BROLLO FOR PEDAL	1

Belt SFG 500 B

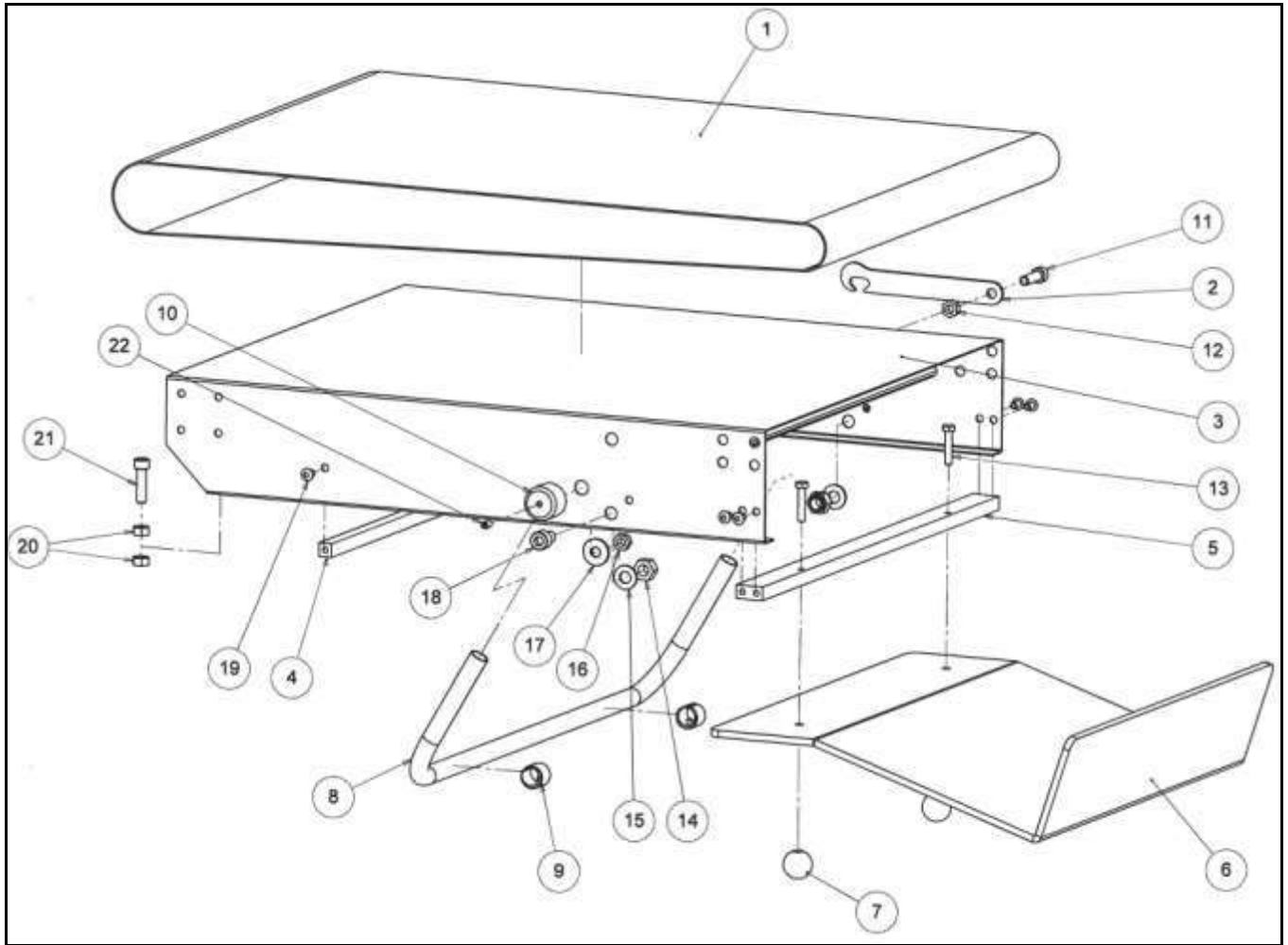

Belt SFG 500 B Table

Pos.	Drawing	Description	Q.ty
1	06001008	BELT	2
2	85174023-3	BELT HOOK	2
3	86174102-1	BELT SHEET METAL	1
4	85174079	SUPPORT SHEET METAL TIE ROD	1
5	85174083	DRAWER	1
6	01174078	PASTA COLLECTOR SHEET METAL	2
7	14002201	KNOB BLACK	2
8	85174084	BELT SUPPORT	2
9	14002671	BLACK FEET	4
10	01174032	BELT SUPPORT PIN	2

Belt SFG 500 T

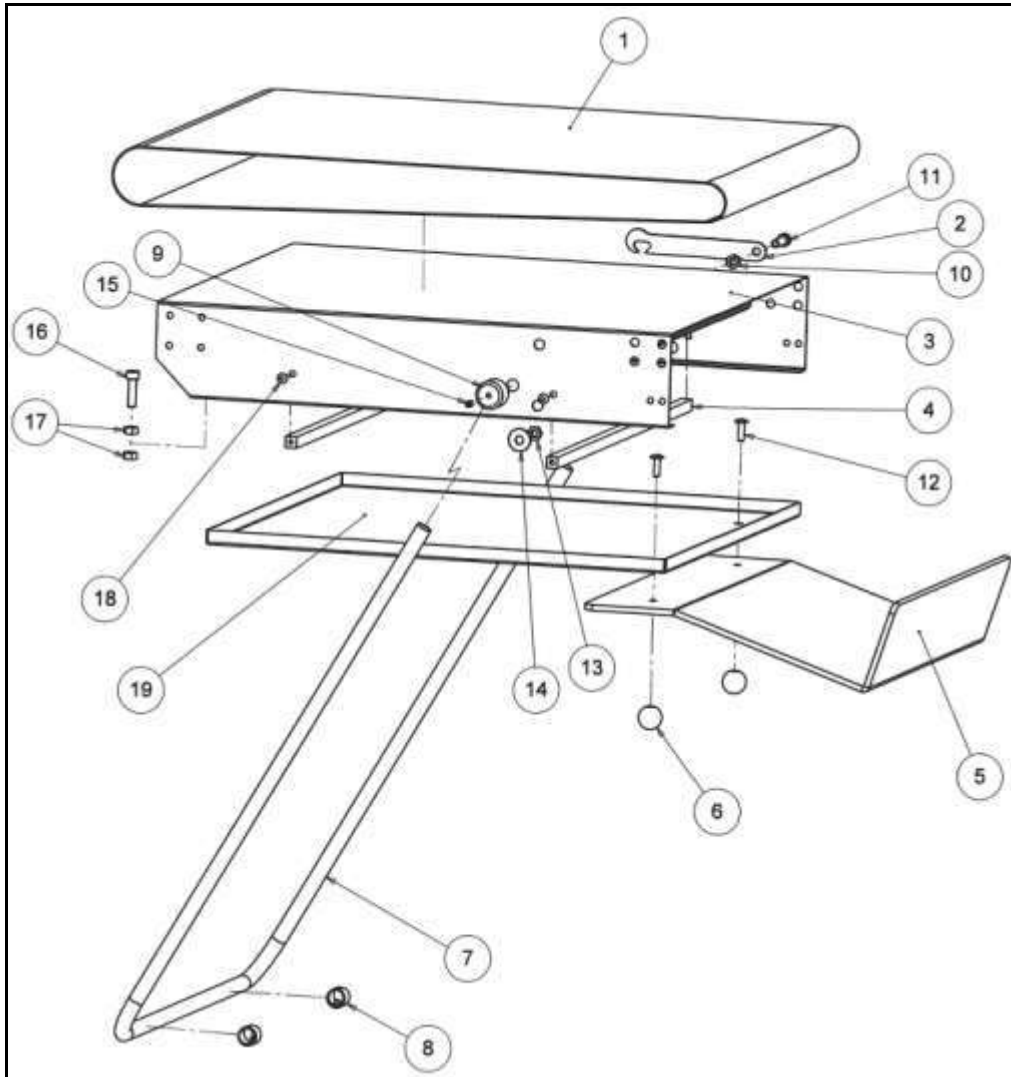

Belt SFG 500 T Table

Pos.	Drawing	Description	Q.ty
1	06001008	BELT	2
2	85174023-3	BELT HOOK	1
3	86174102-1	BELT SHEET METAL	1
4	85174079	SUPPORT SHEET METAL TIE ROD.	2
5	01174078	PASTA COLLECTOR SHEET METAL	1
6	14002201	BLACK KNOB	2
7	85174095	BELT ASSEMBLY SUPPORT	1
8	14002671	BLACK FOOT	2
9	01174032	BELT SUPPORT PIN	2
19	86174077-1	TRAY BELT	2

Belt SFG 500 TM

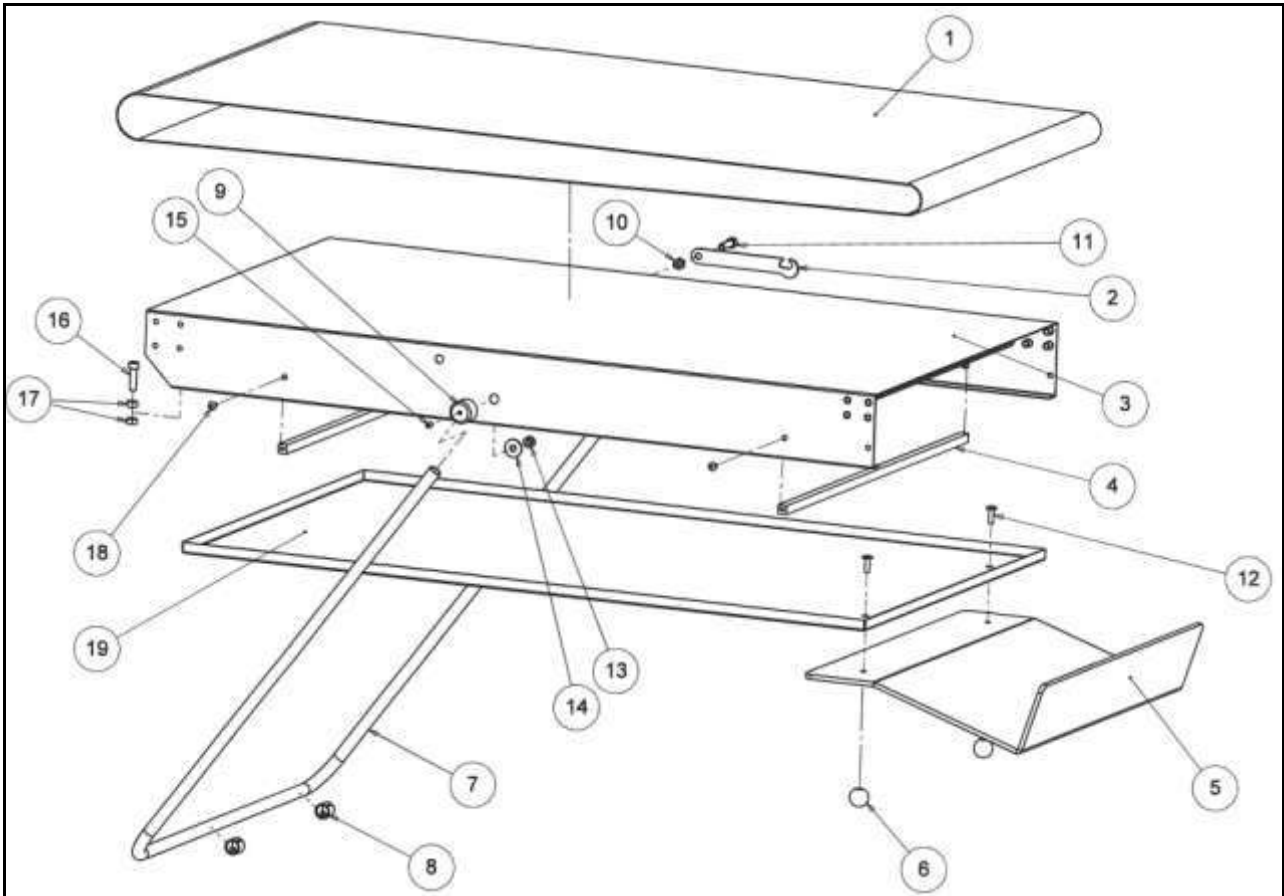

Belt SFG 500 TM Table

Pos.	Drawing	Description	Q.ty
1	06001012	BELT FOR 500 TM	2
2	85174023-3	BELT CONVEYOR HOOK	1
3	86174106	BELT SHEET METAL	1
4	85174079	SUPPORT SHEET METAL TIE ROD.	2
5	01174078	PASTA COLLECTOR SHEET METAL	1
6	14002201	BLACK KNOB	2
7	85174108	BELT ASSEMBLY SUPPORT	1
8	14002671	BLACK FOOT	2
9	01174032	BELT SUPPORT PIN	2
19	86174107	TRAY BELT	2



17. Recommended spare parts

Description	Drawing	Quantity
PEDAL SPRING	08072079	2
BELT HOOK SPRING	08072055	2
ROD WIPER TENSIONING SPRING	08091045	2
ROD WIPER SPRING	08072075	1
HANDLE SPRING	08174040	1
BRAKE LINING	14000941	1
HOOK LEVER	84174142	1
GRADUATED SECTOR	85174036-1	1
MOBILE ROD WIPER	01174087	1
BEARING 6202	13000313	4
BEARING 6204	13000315	2
BEARING 6205	13000316	4
BEARING 6303	13000014	2
BEARING 6304	13000325	1
POLY-V BELT	12003949	1
CHAIN	12000001	2
CHAIN	12000002	1

17.1. Recommended spare parts - electrical parts

Description	Drawing	Quantity
MICRO + LEVER	25001311	1
ELECTRIC BOARD	25001481	1
MASTER SWITCH	25003009	1
MAINS LED	25009027	1

17.2. Recommended spare parts for belts

Description	Drawing	Quantity
BELT SFG 500 B	06001008	2
BELT SFG 500 T	06001008	2
BELT SFG 500 TM	06001012	2

18. Wiring diagram

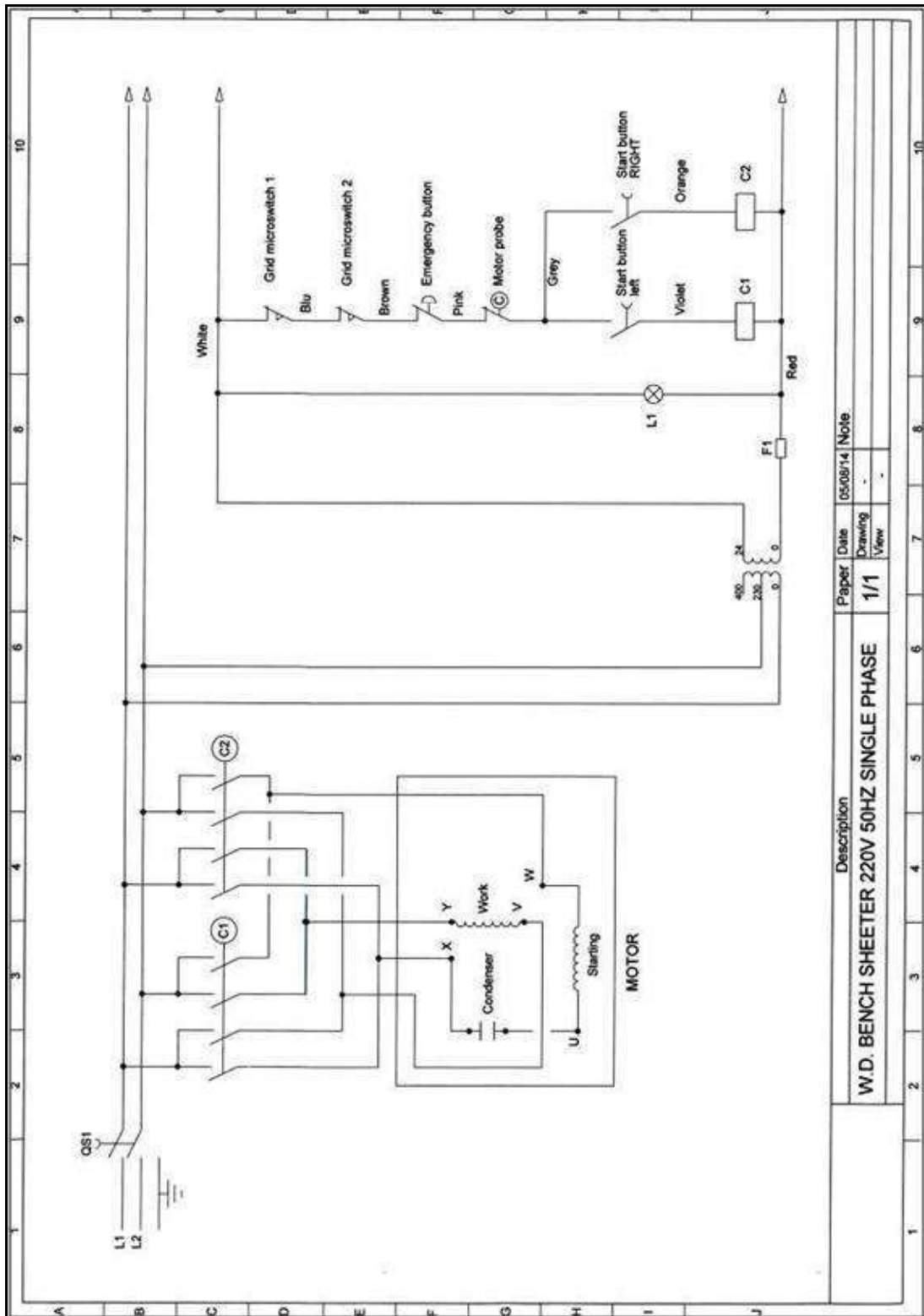

Wiring diagram of single-phase over the counter sheeters

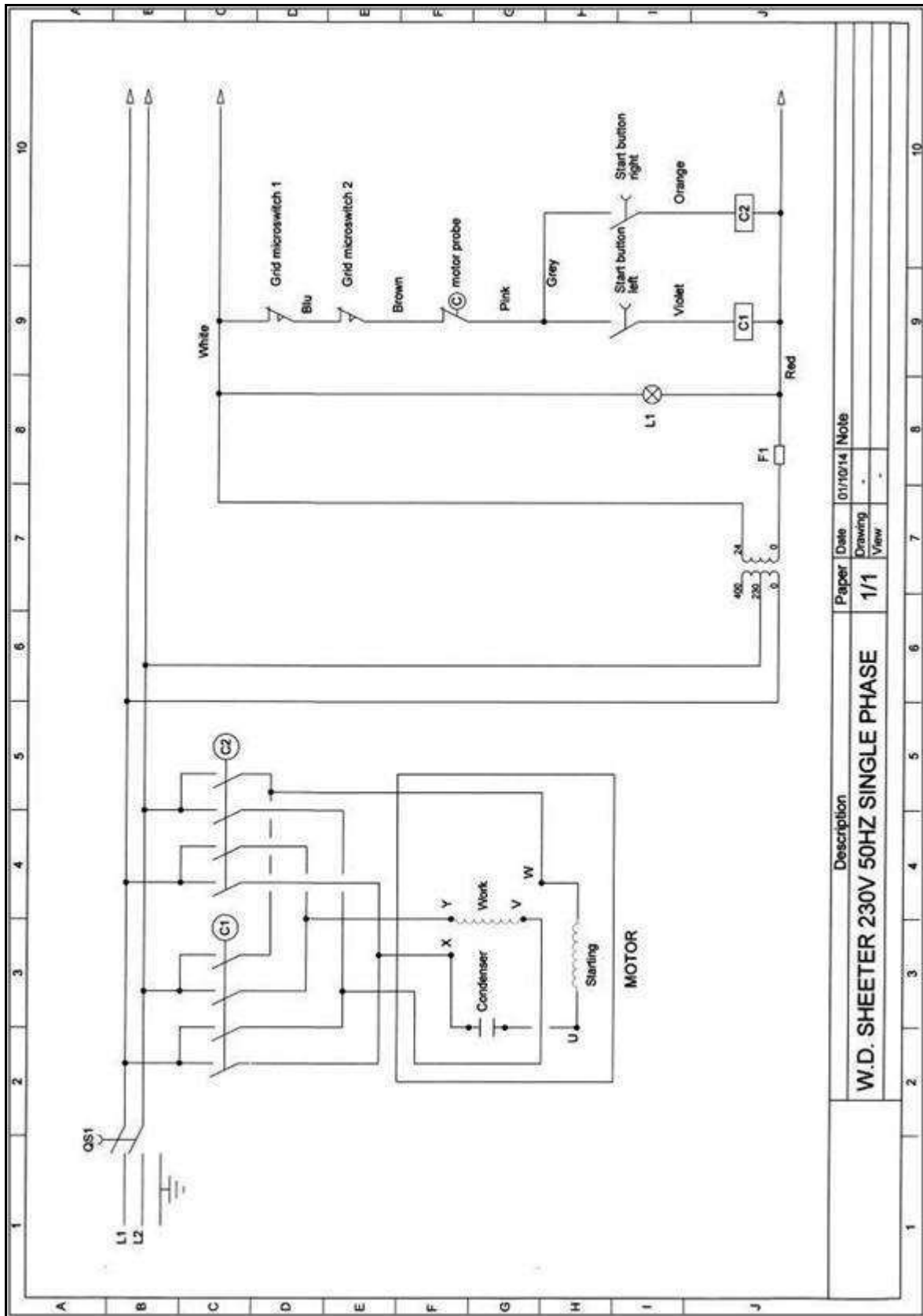

Description		Paper	Date	01/10/14	Note
W.D. SHEETER 230V 50HZ SINGLE PHASE		Drawing	1/1	-	-
		View	-	-	-

Wiring diagram of single-phase sheeters

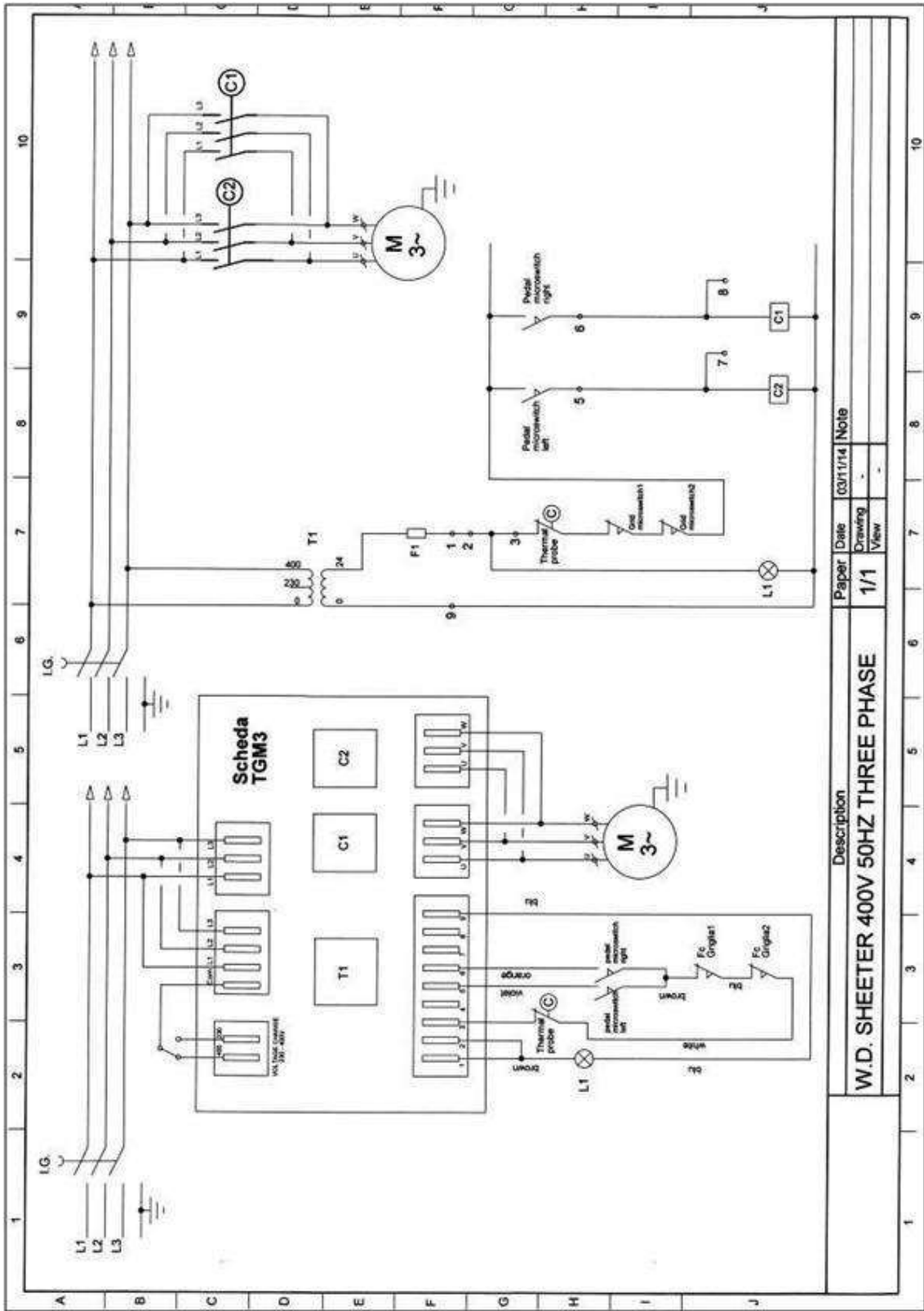

Description		Paper	Date	Note
W.D. SHEETER 400V 50HZ THREE PHASE		1/1	03/11/14	
		View		

Wiring diagram of three-phase sheeters

19. Demolition and disposal

The purchaser is responsible for putting the machine out of service in compliance with the local standards and regulations. Dismantling of mechanical and electrical parts must be entrusted to competent personnel. The electrical system must be dismantled and disposed of through a specialised company.

19.1. Obligations of informing users

Information model for users of "professional" products



INFORMATION FOR USERS

Pursuant to art. 26 of Legislative Decree 14/03/2014, no. 49 "Implementing Directive 2012/19/UE, on waste from electrical and electronic equipment (RAEE), and the disposal of waste"

The symbol of the crossed-out wheeled bin on the appliance or its packaging indicates that the product must be disposed of separately from other waste at the end of its useful life.

Differentiated waste collection of this appliance, having reached the end of its life, is organised and managed by the manufacturer. Users who wish to dispose of this appliance must therefore contact the manufacturer and abide by the system that has been chosen to allow for separate collection of the appliance when reaching the end of its life.

Adequate differentiated waste collection for successive recycling, treatment and environmentally compatible disposal contributes to the prevention of negative effects on the environment and on human health and favours the reuse and/or recycling of the materials making up the appliance.

Illicit disposal of the product by the user entails the application of administrative sanctions foreseen by the standards in force.