

IBE®

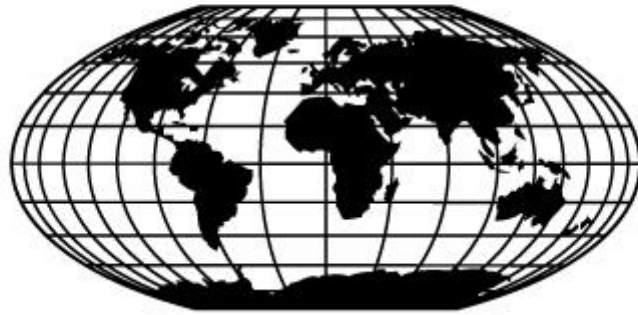

INSTRUCTION MANUAL



TABLE-TOP MINI DOUGH MOULDER

MODEL: T300

Contents

1. General Information:

- 1- Documentation supplied
 - 2- Contact details
 - 3- Use of this manual
 - 4- Intellectual property rights
 - 5- Warranty terms and conditions
 - 6- Machine specifications
 - 7- Machine identification details
 - 8- Main components of the machine
 - 9- Safeguards
-

2. Transport and Installation:

- 1- Transport
 - 2- Installation
 - 3- Testing & Safeguards
-

3. Machine Operation:

- 1- Intended operation
 - 2- Control components
 - 3- Sheeter operation
-

4. Cleaning & Maintenance:

- 1- Cleaning
- 2- Maintenance
- 3- Spare parts list
- 4- Exploded parts drawings
- 5- Electrical diagram

1. General Information:

1.1 Documentation supplied

- Instruction manual
 - Spare Parts List
 - Wiring diagrams
-

1.2 Contact Details

International Bakery Equipment Pty Ltd (I.B.E.)

Address:

20 Brewer Street
Clontarf QLD 4019
Australia

Phone:

1300 099 011 or + 61 7 3889 5700

E-Mail:

sales@allaboutbakery.com.au

Web:

www.allaboutbakery.com.au

1.3 Use of this Manual

Please read carefully the information supplied in this manual before installing, operating or carrying out maintenance on this machine.

This manual must be kept in good condition and stored where it can be easily found when required.

1.4 Intellectual Property Rights

This manual contains copyright information. All rights are reserved. No part of this manual can be reproduced or photocopied without prior written permission of International Bakery Equipment Pty Ltd. Permission to use this documentation has only been given to the customer who this manual has been supplied as part of the machine's equipment and only for the purpose of installation, operation and maintenance of the machine to which the manual refers.

International Bakery Equipment Pty Ltd declares that the information contained herein is in accordance with the technical and safety specifications of the machine to which the manual refers. International Bakery Equipment Pty Ltd will not be held responsible for direct or indirect damage or injury to people or objects resulting from the misuse of this documentation or the machine for which it has been intended.

The manufacturer reserves the right to introduce technical modifications or improvements both to the documentation and to the machines without prior notice. The information contained herein refers in particular to the machine specified in section 1.7 "Machine identification details".

1.5 Warranty Terms and Conditions

- Warranty becomes effective from date of delivery.
- Warranty claims may be made by telephone, letter, email or fax. However, all verbal claims must be confirmed in writing. I.B.E. Pty Ltd Reserves the right to require return of all claimed defective parts.
- I.B.E. Pty Ltd will ship the part(s) in an expeditious manner as requested.
- Mechanical and Electrical parts are warranted for a period of 12 months from date of delivery.
- During the first 12 months, I.B.E. Pty Ltd will reimburse the Authorized Agent or Purchaser for the cost of reasonable labour during normal working hours, 8.00a.m. – 5.00p.m., to remove the failed part(s) and install the replacement(s). After 12 months all charges will be the Purchasers responsibility.
- After the initial 12 months warranty, any replacement parts are warranted for 3 months excluding labour.
- This Warranty may not be changed or modified and is not subject to any other Warranty expressed or implied by any other Agent, Dealer or Distributor unless approved in writing by I.B.E. Pty Ltd in advance of any claim being filed. This Warranty gives you specific legal rights which vary from State to State.

Note:

I.B.E. Pty Ltd reserves the right to make the final decision on all Warranty coverage questions. The decision of the Company is final.

What is covered under this Warranty:

- Parts that fail due to defects in material workmanship.
- Parts that fail due to faulty assembly by I.B.E. Pty Ltd
- Parts that fail due to improper set-up by I.B.E. Pty Ltd

What is not covered under this Warranty:

- Parts that fail due to improper usage or overloading of the machine.
- Parts that fail due to lack of maintenance.
- Parts that fail due to abuse, misuse or modification.
- Mixer attachments - Bowl, whisk, beater and/or hook.
- Normal wear parts, such as, Conveyor belts, 'v' belts, 'o' rings and scraper and slicer blades. The Warranty on these parts is, they will be in satisfactory operating condition at time of delivery and initial start-up. Claims in such parts must be made immediately.
- Loss of time, potential revenue and/or profits.
- Personal injury or property damage resulting from the operation of the machine.

1.6 Specifications

Crate Dimensions:

Length (cm)	Width (cm)	Height (cm)	Weight (Kg)
100	70	70	90

Machine Specifications

Model	Motor H.P.	Dimensions			Weight Kg (Net)
		L cm	W cm	H cm	
T300	¼	90	58	49	60

Power Supply Details:

Single Phase, 10amp 3-pin plug top (supplied)

Note:

The Manufacturer will not be Liabable for electrical defects, breakdowns or malfunctioning of the machine for the non compliance with the power supply stated.

1.7 Machine Identification Details

Type: Table-Top Mini Dough Moulder

Model: T300

Position of Serial Number Identification Plate (Fig 1.1)



Fig 1.1

Note:

When requesting spare parts please state the serial number found on the serial number identification plate.

1.8 Main Machine Components

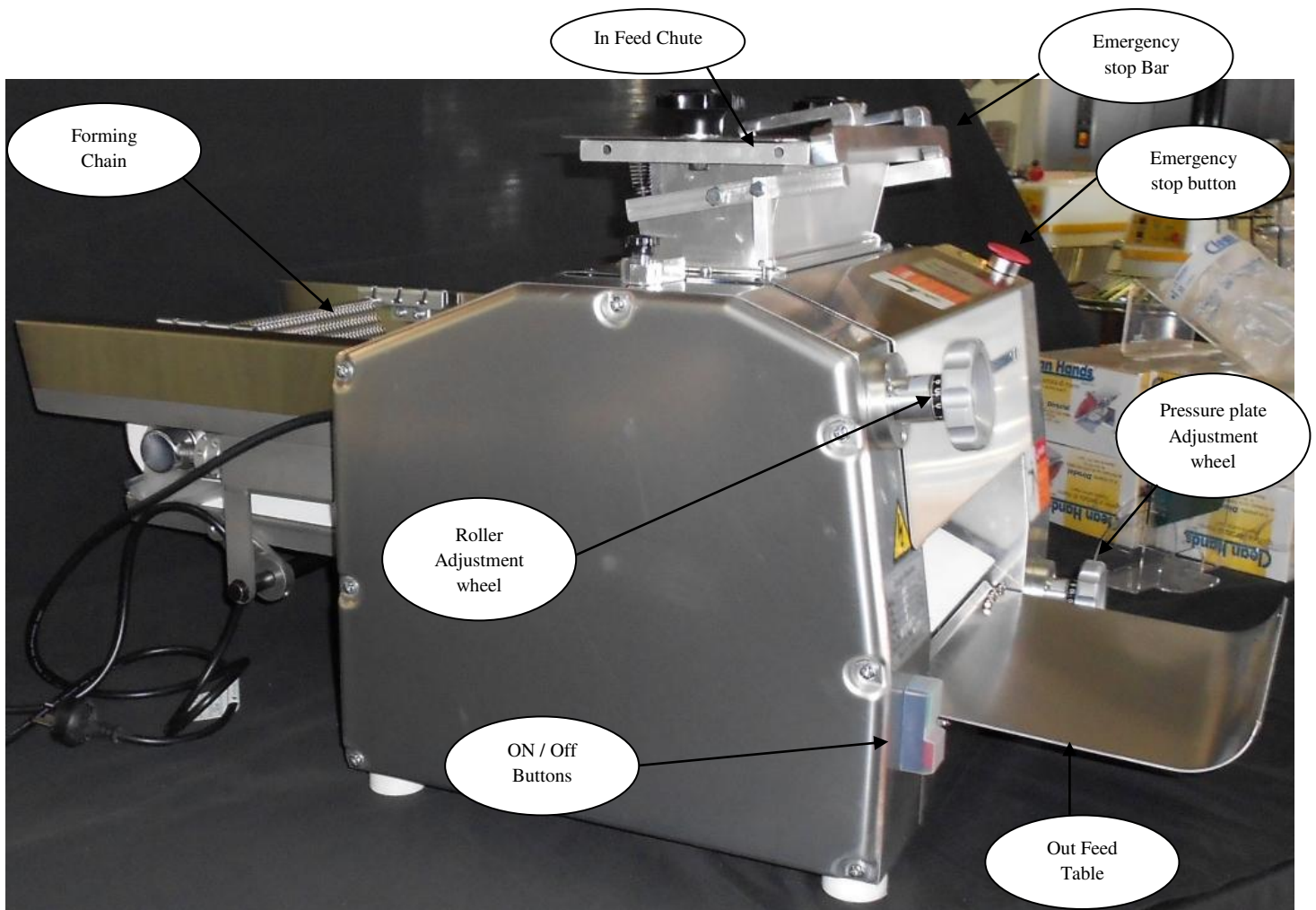

Fig1.2 Main Machine Components

1.9 Safeguards

This machine has been fitted with safeguards to ensure safe operation of this machine, in accordance please ensure the following;

- Do not place foreign objects on or under the belts.
- Ensure training in the safe operation of this machine is carried out with all operators.
- Do not wear loose clothing, ties, chains, or watches that could get caught into the moving parts of the machine.
- Ensure safeguards are in operable order before using the machine on a daily basis.
- Tampering with the safety devices creates hazards for the machine operator, for which International Bakery Equipment Pty Ltd or its agents will not be liable.

Note:

In the event that one or more of the safe guards do not operate or fail contact your supplier immediately. **DO NOT OPERATE THE MACHINE.**

Tampering with or modifying the machine will void warranty.

Emergency Stop Button.

The machine is equipped with a red emergency stop button located on the right panel of the machine and allows the operator to stop the machine in case of emergency see Fig 1.2

Limit switched in-feed chute.

The front of the in-feed chute is fitted with a limit switch emergency stop bar, when the bar is pressed down the machine will stop immediately; the green start button must be pressed for the machine to operate again. (Fig 1.3)



Fig1.3 In feed chute showing Emergency Stop Bar.

2. Transport and Installation:

2.1 Transport

The instructions given in this section must be carefully followed when transporting the machine. This operation may include but is not limited to the following:

- Storage of the machine
- Installation of the machine
- The machine comes supplied in a secure packing crate which needs to be handled with care to protect the machine.
- When being transported the machine crate should be secure to the transporting vehicle using approved tie down straps to avoid the machine tipping over.
- The machine should not be placed on top of other items during transport.
- When lifting the machine ensure all persons are at a safe distance.
- The forklift operator is to hold the appropriate qualifications.
- Do not climb on or place body under machine crate when it is being lifted from the ground or transport vehicle.
- When lifting the machine crate ensure forks are spread to the maximum width of the crate and the crate is against the cradle of the forklift (Fig2.1).



Fig 2.1

2.2 Installation

- Ensure transport crate and all protective packaging is removed.
 - Carefully clean the machine using a damp clean cloth, removing dust on all surfaces.
 - When the machine has been unpacked, check the condition of the machine. Any visible damage indicates that the machine has been dropped or hit by something during transport. This could lead to malfunctioning. If damage has occurred during transport it should be attributed to the carrier and International Bakery Equipment Pty Ltd or its agent should be informed immediately of the situation.
 - Locate the moulder in a convenient position on a flat level bench, where the operation of the machine is safe and accessible.
 - Before making the electrical connections check the specifications found in section 1.6 of this manual and ensure they match those of your electrical service.
 - Make certain the electrical supply is correct and the correct breaker is in place to ensure protection from a short circuit.
 - A qualified person should correct electrical connection if required.
 - Train all operators in the safe operation of this machine.
-

2.3 Testing the safeguards

Before starting the machine, the safety devices should be checked according to the following procedure:

- Correct operation of the emergency stop bar limit switch (Fig 1.3, page.9);
While the machine is operating press down on the front of the in-feed chute, the machine should stop immediately.
 - Correct operation of the emergency stop button (Fig 1.2, page.8);
While the machine is operating, press the emergency stop button, the machine should stop immediately.
-

3. Machine Operation:

3.1 Intended Operation

This machine has been designed and manufactured for the final moulding of dough pieces for bread baguettes', French sticks, and long rolls with the use of two sets of stainless steel rollers to express air from the dough piece, moulding chain to form the dough into a cylinder and moulding belt and pressure plate to give the desired length of the final product and to seal the seam.

This machine has been designed and built to operate indoors.

3.2 Control Components

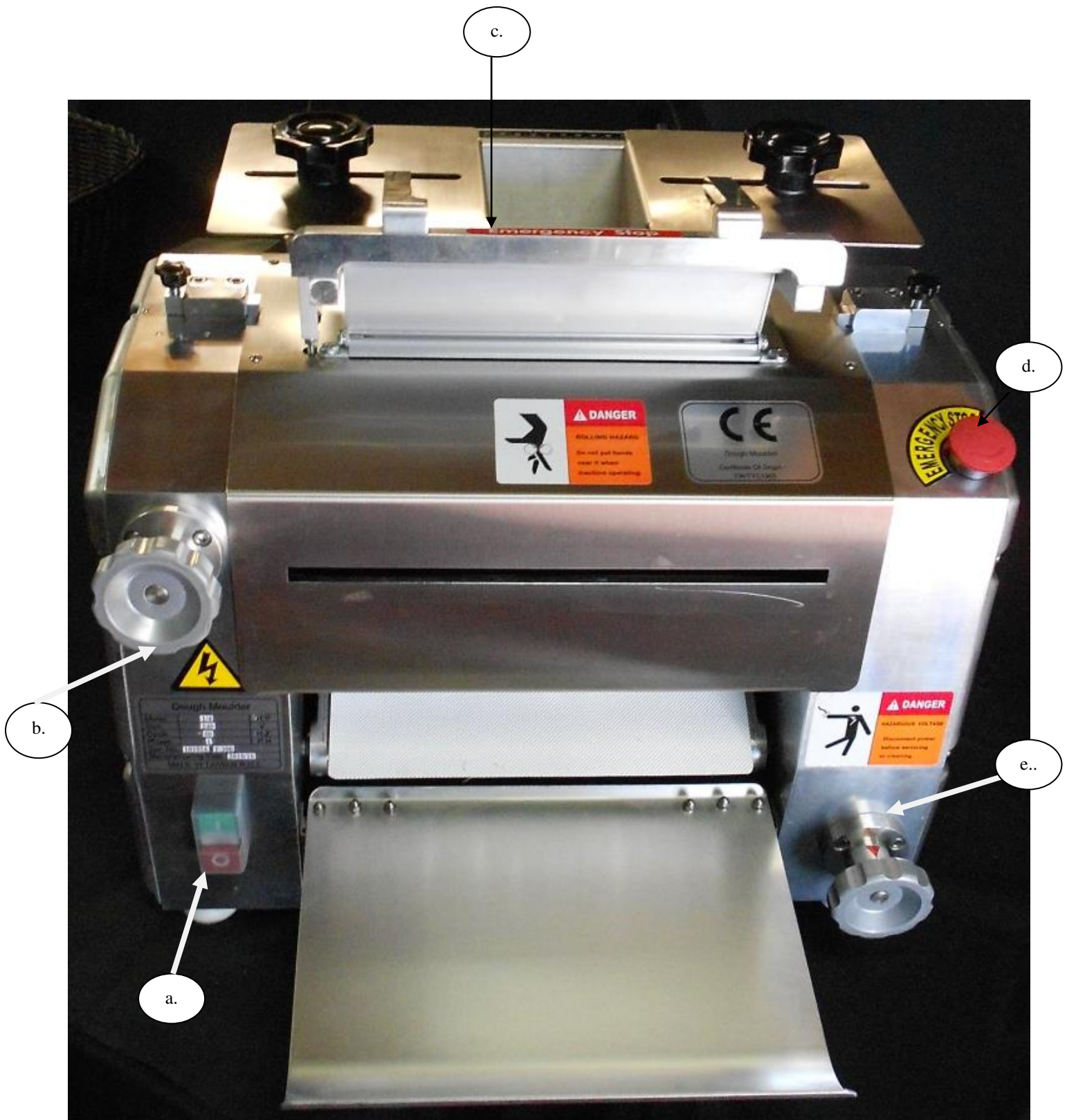

Fig 3.1 T300 Control Components

Location	Description	Operation Performed
a	On / Off Switch	When the green switch is pressed the power is turned on. When the red switch is pressed the power is turned off.
b	Pressure roller adjustment wheel	Sets the gap between the rollers as determined by the operator.
c	Emergency stop bar	When pressed it stops the machine completely.
d	Emergency stop button	When pressed it stops the machine completely.
e	Pressure Plate adjustment wheel	Adjusts the space between the moulding belts and pressure plate depending on the final length of the dough piece desired.

3.3 Moulder Operation

These operating procedures are to be used as a guide, as every bakeries dough consistency is different.

These steps should be used to set up the T-300 to your specific product and by keeping records of the settings it will assist in the day to day operation of this machine, be aware though you may still need to fine tune the settings that you record as your dough can change i.e. longer than normal bench rest, or a slacker dough.

- Pressure roller adjustment wheel (b) closes the gap between the rollers.
- If the dough piece tears the rollers are to close, open rollers further until dough piece does not tear.
- If the dough piece is too loose and the finished baked product has air holes in it the rollers need to be brought in closer.
- Dough piece should be firm once through the rollers.
- The curling chain which lies on the top of the belt assists in forming the dough into the final shape prior to the dough piece dropping and going between the belt and the pressure board.
- If you wish to produce flat bread products the curling chain can easily be un-hooked from the front hangers while the machine is stopped and hung over the rear of the machine or removed, and the flat dough pieces picked up off the belt.
- Pressure plate adjustment wheel (e) opens and closes the gap between the belt and pressure board.
- This board determines the final length of the product and helps seal the seam of the product.
- If your product is too long open the gap wider.
- If your product is too short the gap should be brought in closer.

4. Cleaning & Maintenance:

4.1 Cleaning

- Always turn power off at the wall and unplug machine prior to cleaning or maintenance.
- This machine should be cleaned at the end of every day, to prevent a build up of dough crumb and flour dust.
- Remove upper cover. See Fig (4.1)
- Clean any hard dough crumb from pressing rollers with a plastic scraper flour dust can be removed with a brush
- Wipe over with a damp cloth (not dripping wet)
- While cover is off the machine it can be dusted off with a brush and wiped over with a damp cloth.
- Body of the machine can be dusted off and wiped over with a damp cloth.
- Replace upper cover.
- While cleaning the machine check for any wear on belts.
- If the machine starts operating strangely (different sound, belt slipping) during normal operation please contact a qualified technician as soon as possible



Fig.4.1 T300. With top cover removed.

Note:

Do not use water jets or hoses to clean this machine as excess water can damage the machine, and the safe operation of the electrical components.

4.2 Maintenance

It is recommended that this machine should be serviced once every 12 months by a qualified technician to maintain hassle free operation.

If in the event the machine does not operate correctly it is recommended that you contact your supplier to ensure a qualified technician services the machine for you.

It is not advisable to attempt any repairs without prior knowledge of the mechanical or electrical systems used in the manufacture of this machine, use only qualified technicians.

Note:

Any attempt to modify this machine in any way will result in the warranty being voided.

Tampering with the mechanical or electrical systems in this machine will void warranty.

4.3 Spare Parts List

No.	Description
1	Gear 15T
2	Gear 12T
3	Bearing Housing
4	Shaft
5	Gear
6	Cam
7	Adjusting wheel
8	N/A
9	Bearing
10	Driving Roller
11	Worm gear
12	Passive Roller
13	Upper cover
14	Bearing
15	Pressing Roller
16	Pressing Roller
17	Spring
18	Roller Holder
19	Roller Holder
20	Adjusting Wheel
21	Scraper Base
22	Bearing

No.	Description
23	Bearing Housing
24	N/A
25	Chain Adjuster
26	Emergency Stop
27	Conveyor
28	Pressure Plate
29	Turn over plate
30	Forming Chain
31	Switch
32	Product Outfeed Tray
33	Gear 10T
34	Motor

4.4 Exploded Parts Drawing

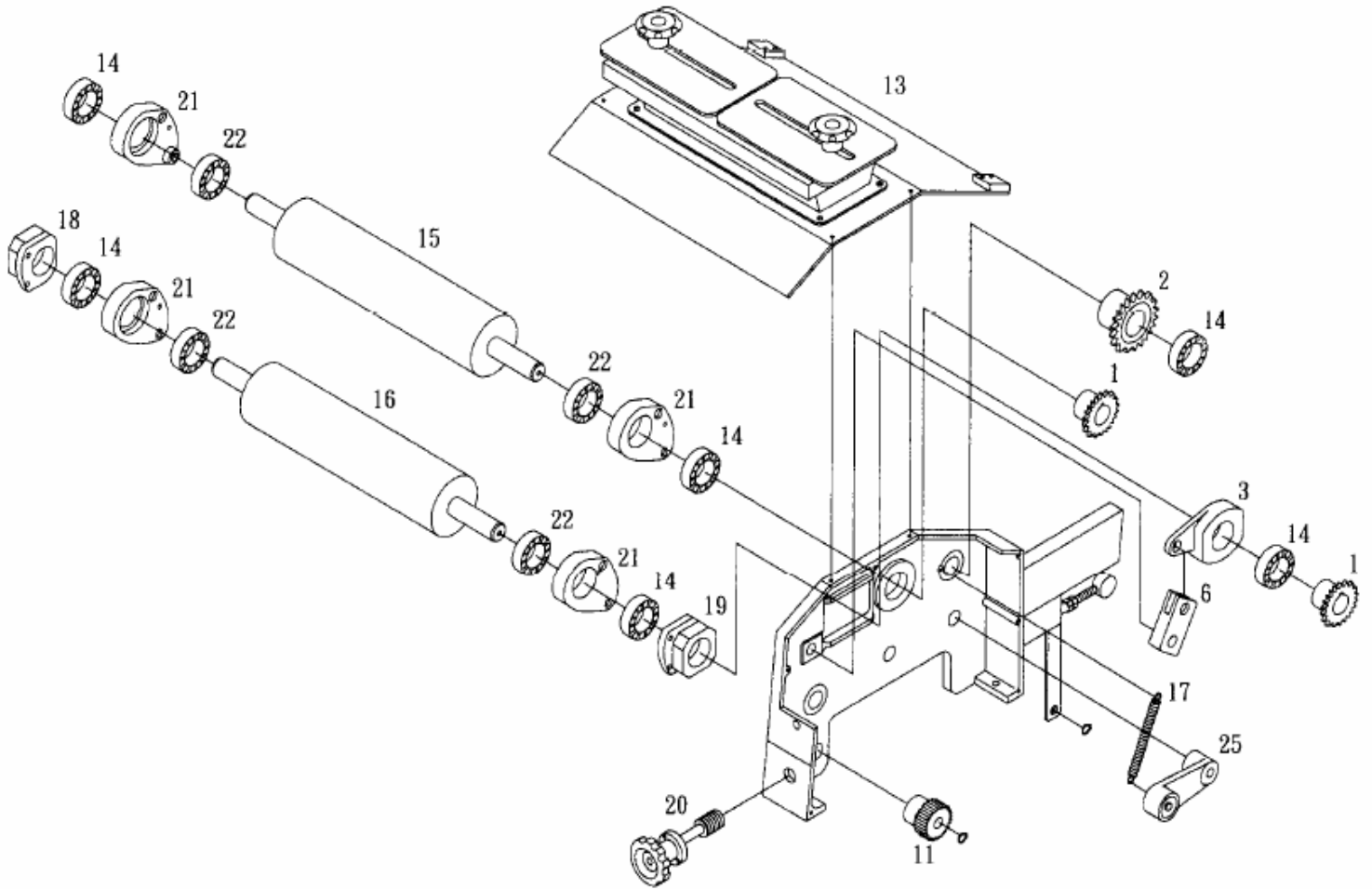

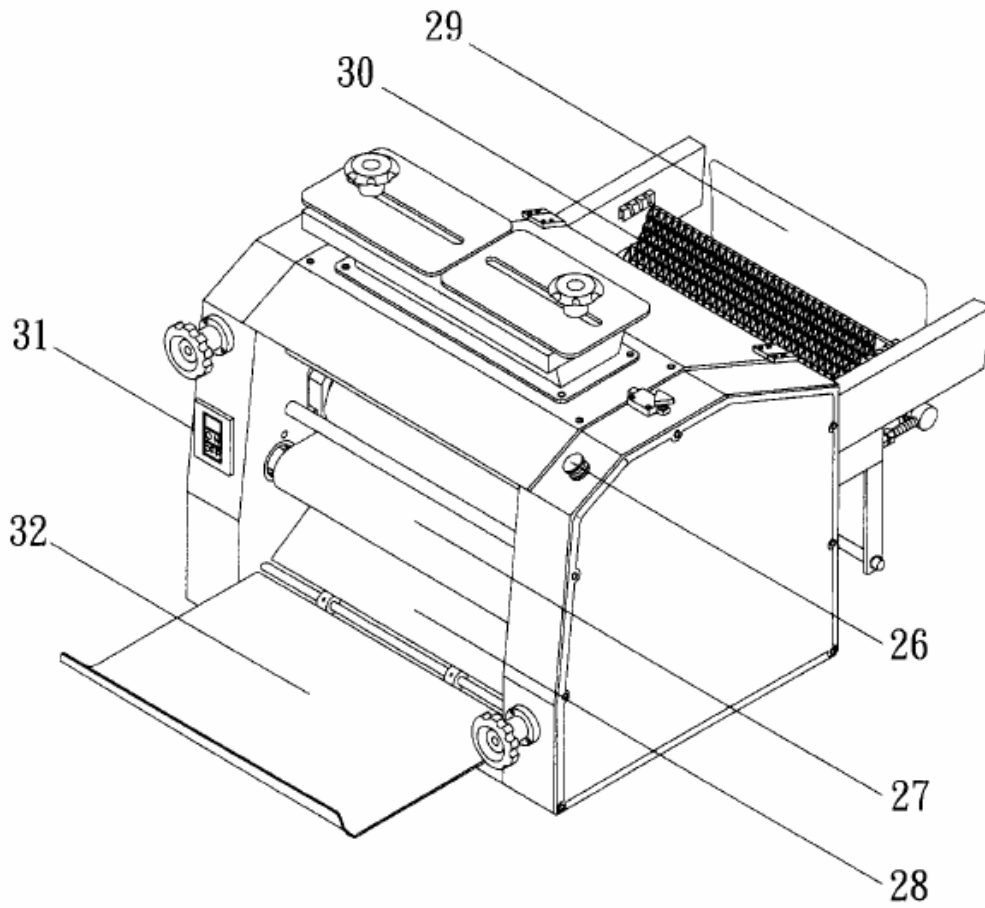

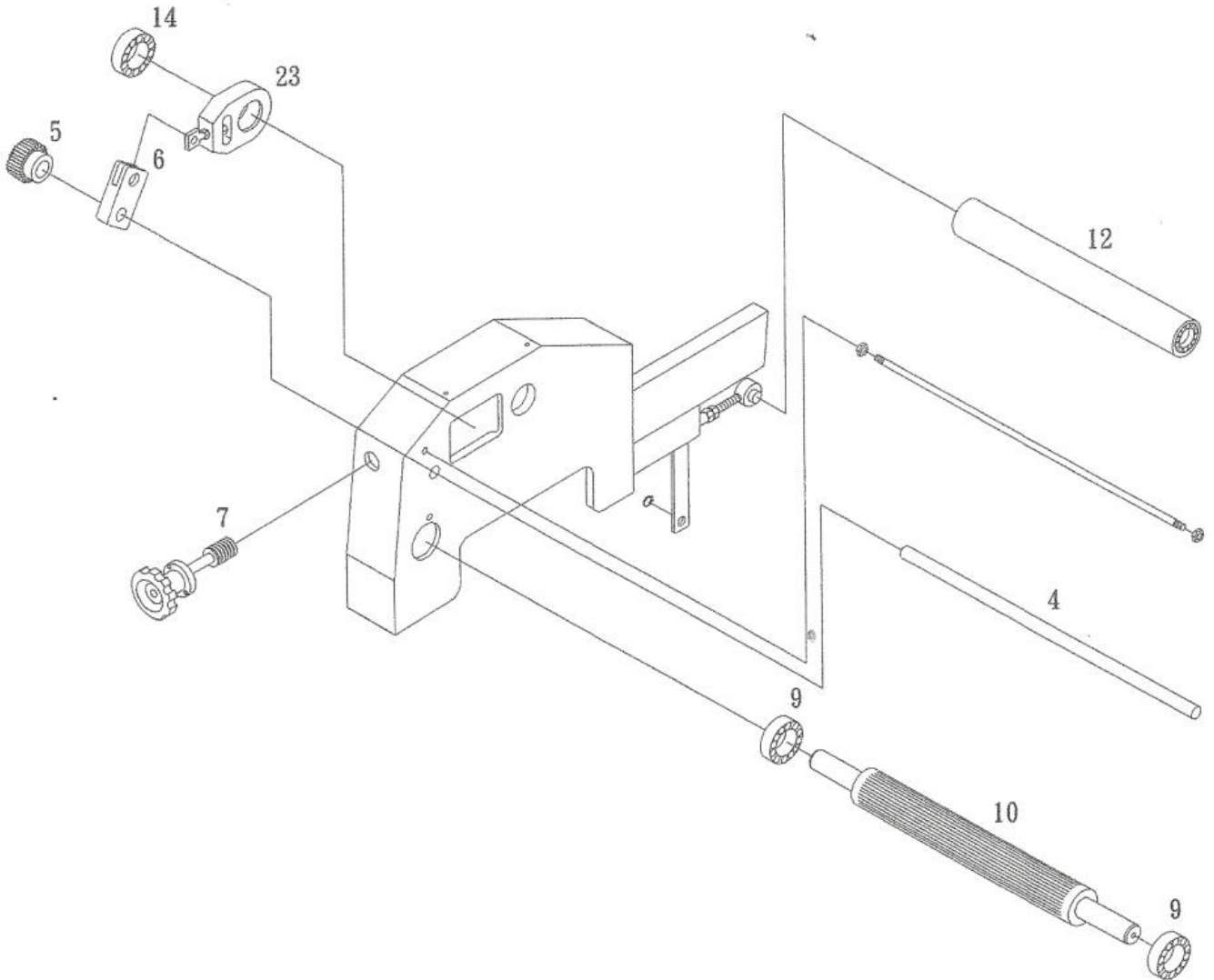

4.5 Electrical Wiring Diagram

