

IBE[®]

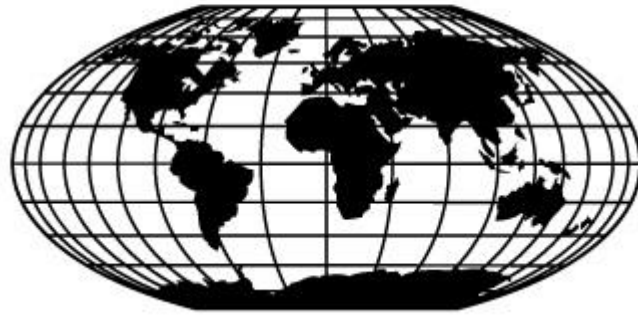

INSTRUCTION MANUAL



40lt Planetary Mixer

MODEL: TF40B/TF40-HP

Contents

1. General Information:

- 1- Documentation supplied
 - 2- Contact details
 - 3- Use of this manual
 - 4- Intellectual property rights
 - 5- Warranty terms and conditions
 - 6- Machine specifications
 - 7- Machine identification details
 - 8- Main components of the machine
 - 9- Safeguards
-

2. Transport and Installation:

- 1- Transport
 - 2- Installation
 - 3- Testing & Safeguards
-

3. Machine Operation:

- 1- Intended operation
 - 2- Control components
 - 3- Sheeter operation
-

4. Cleaning & Maintenance:

- 1- Cleaning
- 2- Maintenance
- 3- Spare parts list
- 4- Exploded parts drawings
- 5- Electrical diagram

1. General Information:

1.1 Documentation supplied

- Instruction manual
 - Spare parts list
 - Wiring diagrams
-

1.2 Contact Details

International Bakery Equipment Pty Ltd (I.B.E.)

Address:

20 Brewer Street
Clontarf
Queensland
Australia
4019

Phone:

1300 099 011 or + 61 7 3889 5700

E-Mail:

sales@allaboutbakery.com.au

Web:

www.allaboutbakery.com.au

1.3 Use of this Manual

Please read carefully the information supplied in this manual before installing, operating or carrying out maintenance on this machine.

This manual must be kept in good condition and stored where it can be easily found when required.

1.4 Intellectual Property Rights

This manual contains copyright information. All rights are reserved. No part of this manual can be reproduced or photocopied without prior written permission of International Bakery Equipment Pty Ltd. Permission to use this documentation has only been given to the customer who this manual has been supplied as part of the machine's equipment and only for the purpose of installation, operation and maintenance of the machine to which the manual refers.

International Bakery Equipment Pty Ltd declares that the information contained herein is in accordance with the technical and safety specifications of the machine to which the manual refers. International Bakery Equipment Pty Ltd will not be held responsible for direct or indirect damage or injury to people or objects resulting from the misuse of this documentation or the machine for which it has been intended.

The manufacturer reserves the right to introduce technical modifications or improvements both to the documentation and to the machines without prior notice. The information contained herein refers in particular to the machine specified in section 1.7 "Machine identification details".

1.5 Warranty Terms and Conditions

- Warranty becomes effective from date of delivery.
- Warranty claims may be made by telephone, letter or email. However, all verbal claims must be confirmed in writing. I.B.E. Pty Ltd reserves the right to require return of all claimed defective parts, cost of return freight is not included.
- I.B.E. Pty Ltd will ship the part(s) in an expeditious manner as requested.
- Mechanical and Electrical parts are warranted for a period of 12 months from date of delivery.
- During the first 12 months, I.B.E. Pty Ltd will reimburse the Authorized Agent or Purchaser for the cost of reasonable labour during normal working hours, 8.00a.m. – 5.00p.m., to remove the failed part(s) and install the replacement(s). After 12 months all charges will be the Purchasers responsibility.
- After the initial 12 months warranty, any replacement parts are warranted for 3 months excluding labour.
- This Warranty may not be changed or modified and is not subject to any other Warranty expressed or implied by any other Agent, Dealer or Distributor unless approved in writing by I.B.E. Pty Ltd in advance of any claim being filed. This Warranty gives you specific legal rights which vary from State to State.

Note:

I.B.E. Pty Ltd reserves the right to make the final decision on all Warranty coverage questions. The decision of the Company is final.

What is covered under this Warranty:

- Parts that fail due to defects in material workmanship.
- Parts that fail due to faulty assembly by I.B.E. Pty Ltd
- Parts that fail due to improper set-up by I.B.E. Pty Ltd

What is not covered under this Warranty:

- Parts that fail due to improper usage or overloading of the machine.
- Parts that fail due to lack of maintenance.
- Parts that fail due to abuse, misuse or modification.
- Mixer attachments - Bowl, whisk, beater and/or hook.
- Normal wear parts, such as, conveyor belts, 'v' belts, 'o' rings and scraper and slicer blades. The Warranty on these parts is, they will be in satisfactory operating condition at time of delivery and initial start-up. Claims in such parts must be made immediately.
- Loss of time, potential revenue and/or profits.
- Personal injury or property damage resulting from the operation of the machine.

1.6 Specifications

Crate Dimensions:

Length (cm)	Width (cm)	Height (cm)	Weight (Kg)
103	66	145	240

Machine Specifications

Model	Bowl Capacity Lt	Motor H.P.	First Speed R.P.M	Second Speed R.P.M	Third Speed R.P.M	Dimensions			Weight Kg (Net)
						L cm	W cm	H cm	
TF40B	40	1 ½	115	231	446	68	54	128	200

Power Supply Details:

Single Phase, 10amp 3-pin plug top (supplied)

Note:

The Manufacturer will not be Liabile for electrical defects, breakdowns or malfunctioning of the machine for the non-compliance with the power supply stated.

1.7 Machine Identification Details

Type: Planetary Mixer

Model: TF40B

Position of Serial Number Identification Plate (Fig 1.1)



Fig 1.1

Note:

When requesting spare parts please state the serial number found on the serial number identification plate.

1.8 Main Machine Components

- Body of the Machine (Fig 1.2)
- Stainless Steel Bowl (Fig 1.3)
- Gear Selector (Fig 1.4)
- Attachments - Beater, Whisk and Hook (Fig 1.5)



Fig1.2



Fig1.3



Fig1.4



Fig 1.5

1.9 Safeguards

This machine has been fitted with safeguards to ensure safe operation of this machine, in accordance please ensure the following;

- Do not place foreign objects in the bowl during the mixing cycle.
- Ensure training in the safe operation of this machine is carried out with all operators.
- Do not wear loose clothing, ties, chains, or watches that could get caught into the moving parts of the machine.
- Ensure safeguards are in operable order before using the machine on a daily basis.
- Tampering with the safety devices creates hazards for the machine operator, for which International Bakery Equipment Pty Ltd or its agents will not be liable.

Note:

In the event that one or more of the safe guards do not operate or fail contact your supplier immediately. **DO NOT OPERATE THE MACHINE.**

Tampering with or modifying the machine will void warranty.

Emergency Stop Button.

The machine is equipped with a red emergency stop button located on the right panel of the machine and allows the operator to stop the machine in case of emergency. (Fig 1.6)



Fig 1.6

Note:

If the emergency stop button is depressed, do not try to pull it out as this may result in damage to the button, to reset the button turn it clockwise and it will reset out on its own.

Limit switched Safety cover.

The safety guard of this machine is fitted with a limit switch which will stop the machines operation when the guard is opened. (Fig 1.7)



Fig 1.7 Safety guard in closed position

Limit switched bowl Lift.

The bowl lift cradle of this machine has been fitted with a limit switch which will stop the machines operation if the bowl is lowered (Fig1.8)



Limited
Switched
Bowl Lift

Fig 1.8 Bowl lift cradle in the raised position.

2. Transport and Installation:

2.1 Transport

The instructions given in this section must be carefully followed when transporting the machine. This operation may include but is not limited to the following:

- Storage of the machine
- Installation of the machine
- The machine comes supplied in a secure packing crate which needs to be handled with care to protect the machine.
- When being transported the machine crate should be secure to the transporting vehicle using approved tie down straps to avoid the machine tipping over.
- The machine should not be placed on top of other items during transport.
- When lifting the machine ensure all persons are at a safe distance.
- The forklift operator is to hold the appropriate qualifications.
- Do not climb on or place body under machine crate when it is being lifted from the ground or transport vehicle.
- When lifting the machine crate ensure forks are spread to the maximum width of the crate and the crate is against the cradle of the forklift (Fig2.1).



Fig 2.1

2.2 Installation

- Ensure transport crate and all protective packaging is removed.
- Carefully clean the machine using a damp clean cloth, removing dust on all surfaces.
- When the machine has been unpacked, check the condition of the machine. Any visible damage indicates that the machine has been dropped or hit by something during transport. This could lead to malfunctioning. If damage has occurred during transport it should be attributed to the carrier and International Bakery Equipment Pty Ltd or its agent should be informed immediately of the situation.
- Locate the mixer in a convenient position on a flat level surface, where the operation of the machine is safe and accessible.
- Before making the electrical connections check the specifications found in section 1.6 of this manual and ensure they match those of your electrical service.
- Make certain the electrical supply is correct and the correct breaker is in place to ensure protection from a short circuit.
- A qualified person should correct electrical connection if required.
- Train all operators in the safe operation of this machine.

2.3 Testing the safeguards

Before starting the machine, the safety devices should be checked according to the following procedure:

- Correct operation of the emergency stop button (Fig 1.6, page.9);
While the machine is operating, press the emergency button, the machine should stop immediately.
- Correct operation of the safety limit switches (Fig 1.7, page.10);
While the machine is operating open the safety guard, the machine should stop immediately.
- Correct operation of the safety limit switches (Fig 1.8, page.10);
While the machine is operating lower the bowl cradle with the stainless-steel bowl in its position, the machine should stop immediately.

3. Machine Operation:

3.1 Intended Operation

This machine has been designed and manufactured for the safe mixing of cake batters, muffin batters and whipping creams and icings.

The use of one of the appropriate attachments and machine speed accordingly to achieve the desired results of a more uniform texture in the final product.

This machine has been designed and built to operate indoors.

Note:

This machine is not intended for the mixing of dough.

Note:

The intended use of this mixer outside of these guidelines may void warranty.

3.2 Control Panel Components

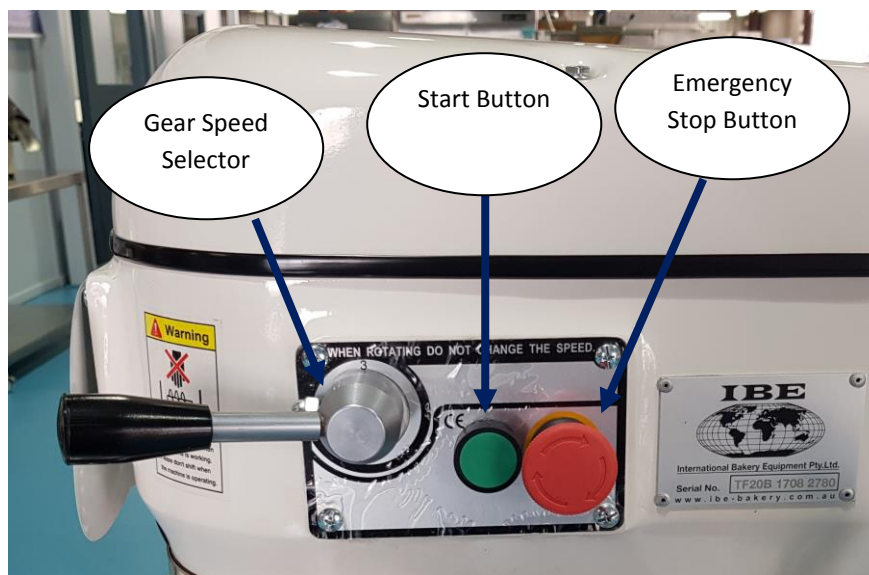

Fig 3.1 TF40B Control Panel

Location	Description	Operation Performed
a	Gear Speed Selector	Controls the speed of the machine as set by the operator. When changing the speed - the machine should be stopped.
b	Start Button	Starts the machine when the bowl is in the raised position and the safety guard is closed.
c	Emergency Stop Button	When pressed, it stops the machine completely.

3.3 Operation

- Place the ingredients in the bowl with the appropriate attachment.
- Place the bowl in the cradle being sure to locate the bowl lug into the position on the cradle and lock the bowl with the lock wings.

- Slide the attachment up on the shaft and turn it until the drive pin in the shaft reaches the L-Shaped slot in the attachment shank.
- Raise the bowl using the hand wheel, ensuring that the bowl is fully raised.
- Close the safety guard completely.
- Select appropriate gear speed and press the green start button (Fig 3.1, B).
- The machine will now operate until the emergency stop button is pressed, the safety guard is opened or the bowl is lowered.
- When changing gears, open the safety guard to stop the machine, change to the new speed, close the guard and press the green start button (Fig 3.1, b) to recommence machine operation.

Note:

Machine must be stopped before changing speeds, failure to do so could result in damaging the machine and voiding warranty.

4. Cleaning & Maintenance:

4.1 Cleaning

- Always turn power off at the wall and unplug machine prior to cleaning or maintenance.
- Keeping the machine cleaned helps to maintain the efficient hassle-free operation of the machine.
- This machine should be cleaned at the end of every day, to prevent a build up of cake batter etc.
- Remove excess flour dust with a soft brush.
- Use a plastic scraper to remove any cake remnants from the machine body.
- Wipe over the entire machine with a damp cloth with a neutral detergent. Harsh chemicals will damage the machine.
- Stainless steel bowls and attachments can be washed in the sink with other utensils.

Note:

Do not use water jets or hoses to clean this machine as excess water can damage the machine, and the safe operation of the electrical components.

4.2 Maintenance

It is recommended that this machine should be serviced once every 12 months by a qualified technician to maintain hassle free operation.

If in the event the machine does not operate correctly it is recommended that you contact your supplier to ensure a qualified technician services the machine for you.

It is not advisable to attempt any repairs without prior knowledge of the mechanical or electrical systems used in the manufacture of this machine, use only qualified technicians.

Note:

Any attempt to modify this machine in any way will result in the warranty being voided.

Tampering with the mechanical or electrical systems in this machine will void warranty.

4.3 Spare Parts List

<i>NO.</i>	<i>PART NAME</i>	<i>NO.</i>	<i>PART NAME</i>
1	Upper Lid	25	Change Speed Lever
2	Time Belt	26	Belt Shaft 13T
3	Case-Transmission	27	Ball Bearing 6204ZZ
4	Switch	28	Gear High Middle - lowspeed
5	Change Speed Handle	28-1	Gear High Speed 46T
6	Handle	29	Planetary Shaft
7	Bowl Handle	30	Ball Bearing 6207ZZ
8	Bowl Support	31	Oil Seal
9	Column	32	Iron Ring
10	Sole	33	Ring Gear 70T
11	Pulley Big	34	Gear 23T
12	Pulley Small	35	Ball Bearing 6205ZZ
13	Motor	36	Planetary Head
14	Ball Bearing 6204ZZ	37	Ball Bearing 6006ZZ
15	Ball Bearing 6204ZZ	38	Oil Seal
16	Ball Bearing 6204ZZ	39	Planetary Head
17	Gear Housing Cover	40	Iron Ring
18	Iron Ring	41	Bevel Gear
		41-1	Up and Down Shaft
19	Gear Low Speed 34T	42	Link
20	Gear Middle Speed 24T	43	Fixed
21	Gear Shaft 15T	44	Mixer Bowl
22	Ball Bearing 6204ZZ	45	Mixer Hook
23	Shift Gear 14T	46	Mixer Beater

24	Gear Shift Fork	47	Mixer Whipper
----	-----------------	----	---------------

4.4 Exploded Parts Drawing

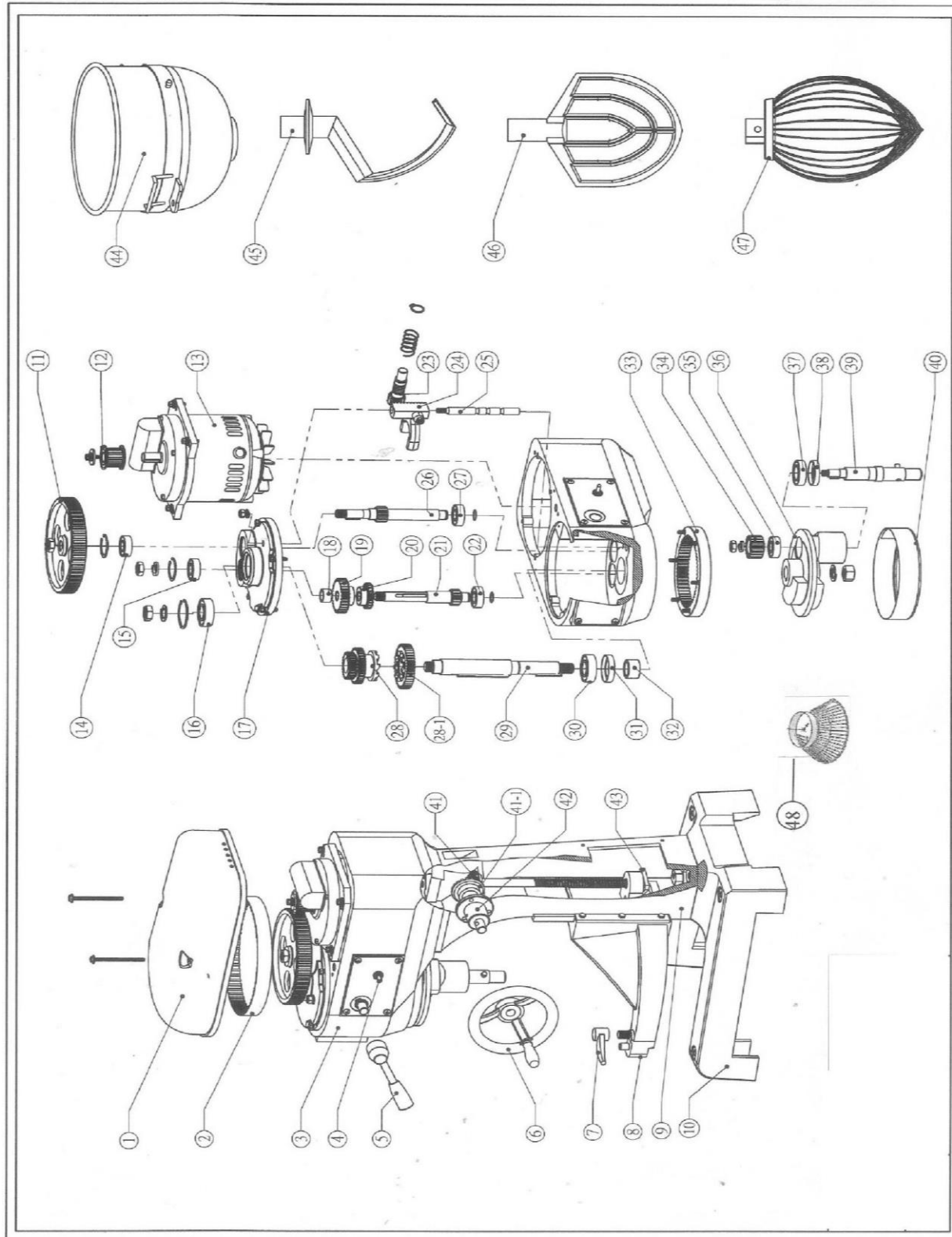

4.5 Electrical Wiring Diagram

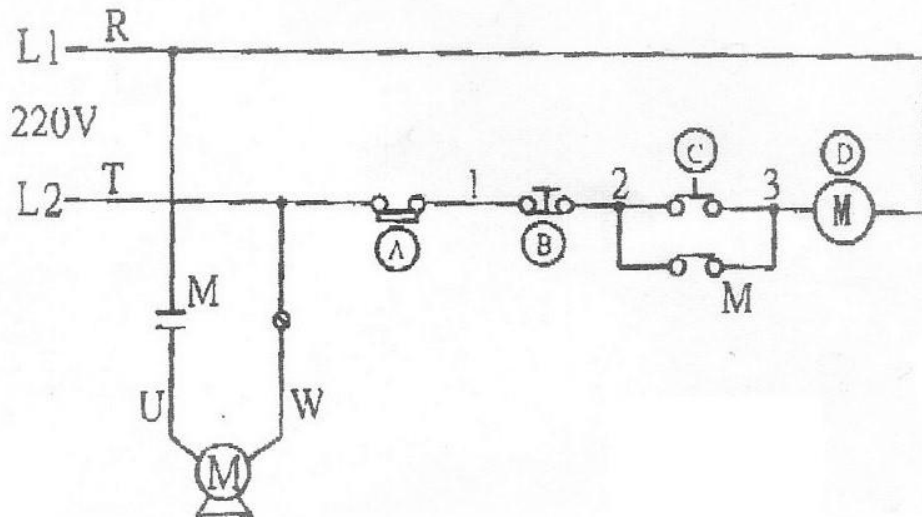

- A Safety Guard Micro Switch
- B Stop
- C Start
- D Contactor